

PEFY-P-VMA-E

1. SPECIFICATIONS.....	1 - 32
2. EXTERNAL DIMENSIONS	1 - 35
3. CENTER OF GRAVITY	1 - 39
4. ELECTRICAL WIRING DIAGRAMS	1 - 40
5. SOUND LEVELS	1 - 41
5-1. Sound levels	1 - 41
5-2. NC curves	1 - 41
6. FAN CHARACTERISTICS CURVES.....	1 - 45
7. OPTIONAL PARTS.....	1 - 53

1. SPECIFICATIONS

DATA G6

PEFY-VMA

Model		PEFY-P20VMA-E	PEFY-P25VMA-E	PEFY-P32VMA-E	PEFY-P40VMA-E
Power source		1-phase 220-230-240V 50Hz	1-phase 220-230-240V 50Hz	1-phase 220-230-240V 50Hz	1-phase 220-230-240V 50Hz
Cooling capacity (Nominal)	*1 kW	2.2	2.8	3.6	4.5
	*1 kcal / h	1,900	2,400	3,100	3,900
	*1 BTU / h	7,500	9,600	12,300	15,400
	*2 Power input kW	0.06	0.06	0.07	0.09
	*2 Current input A	0.53	0.53	0.55	0.64
Heating capacity (Nominal)	*3 kW	2.5	3.2	4.0	5.0
	*3 kcal / h	2,200	2,800	3,400	4,300
	*3 BTU / h	8,500	10,900	13,600	17,100
	*2 Power input kW	0.04	0.04	0.05	0.07
	*2 Current input A	0.42	0.42	0.44	0.53
External finish		Galvanized steel plate	Galvanized steel plate	Galvanized steel plate	Galvanized steel plate
External dimension HxWxD		mm	250 x 700 x 732	250 x 700 x 732	250 x 700 x 732
		inch	9-7/8 x 27-9/16 x 28-7/8	9-7/8 x 27-9/16 x 28-7/8	9-7/8 x 27-9/16 x 28-7/8
Net weight		kg(lbs)	23(51)	23(51)	23(51)
Heat exchanger		Cross fin(Aluminum fin and copper tube)	Cross fin(Aluminum fin and copper tube)	Cross fin(Aluminum fin and copper tube)	Cross fin(Aluminum fin and copper tube)
FAN		Sirocco fan x 1			
*4 External static press.	Pa	<35> - 50 - <70> - <100> - <150>	<35> - 50 - <70> - <100> - <150>	<35> - 50 - <70> - <100> - <150>	<35> - 50 - <70> - <100> - <150>
	mmH ₂ O	<3.6> - 5.1 - <7.1> - <10.2> - <15.3>	<3.6> - 5.1 - <7.1> - <10.2> - <15.3>	<3.6> - 5.1 - <7.1> - <10.2> - <15.3>	<3.6> - 5.1 - <7.1> - <10.2> - <15.3>
Motor Type		DC brushless motor	DC brushless motor	DC brushless motor	DC brushless motor
Motor output kW		0.085	0.085	0.085	0.085
Driving mechanism		Direct-driven by motor	Direct-driven by motor	Direct-driven by motor	Direct-driven by motor
Air flow rate		(Low-Mid-High)	(Low-Mid-High)	(Low-Mid-High)	(Low-Mid-High)
		m ³ / min	6.0 - 7.5 - 8.5	6.0 - 7.5 - 8.5	7.5 - 9.0 - 10.5
		L/s	100 - 125 - 142	100 - 125 - 142	125 - 150 - 175
		cfm	212 - 265 - 300	212 - 265 - 300	265 - 318 - 371
Sound pressure level (measured in anechoic room)		(Low-Mid-High)	(Low-Mid-High)	(Low-Mid-High)	(Low-Mid-High)
*2 dB <A>		23-25-26	23-25-26	23-26-29	23-27-30
Insulation material		EPS, Polyethylene foam, Urethane foam	EPS, Polyethylene foam, Urethane foam	EPS, Polyethylene foam, Urethane foam	EPS, Polyethylene foam, Urethane foam
Air filter		PP honeycomb fabric.	PP honeycomb fabric.	PP honeycomb fabric.	PP honeycomb fabric.
Protection device		Fuse	Fuse	Fuse	Fuse
Refrigerant control device		LEV	LEV	LEV	LEV
Connectable outdoor unit		R410A, R407C, R22 CITY MULTI	R410A, R407C, R22 CITY MULTI	R410A, R407C, R22 CITY MULTI	R410A, R407C, R22 CITY MULTI
Diameter of refrigerant pipe	Liquid (R410A) (R22, R407C)	mm(in.)	6.35(1/4)Braze	6.35(1/4)Braze	6.35(1/4)Braze
		mm(in.)	6.35(1/4)Braze	6.35(1/4)Braze	6.35(1/4)Braze
	Gas (R410A) (R22, R407C)	mm(in.)	12.7(1/2)Braze	12.7(1/2)Braze	12.7(1/2)Braze
		mm(in.)	12.7(1/2)Braze	12.7(1/2)Braze	12.7(1/2)Braze
Field drain pipe size		mm(in.)	O.D.32(1-1/4)	O.D.32(1-1/4)	O.D.32(1-1/4)
Drawing	External	IU-KB94-R528	IU-KB94-R528	IU-KB94-R528	IU-KB94-R528
	Wiring	IU-KB94-R069	IU-KB94-R069	IU-KB94-R069	IU-KB94-R069
	Refrigerant cycle	-	-	-	-
Standard attachment	Document	Installation Manual, Instruction Book	Installation Manual, Instruction Book	Installation Manual, Instruction Book	Installation Manual, Instruction Book
	Accessory	Insulation pipe for refrigerant pipe, Washer, Drain hose, Tie band	Insulation pipe for refrigerant pipe, Washer, Drain hose, Tie band	Insulation pipe for refrigerant pipe, Washer, Drain hose, Tie band	Insulation pipe for refrigerant pipe, Washer, Drain hose, Tie band
Optional parts	Filter box	PAC-KE91TB-E	PAC-KE91TB-E	PAC-KE91TB-E	PAC-KE92TB-E
Remarks		* Details on foundation work, duct work, insulation work, electrical wiring, power source switch, and other items shall be referred to the Installation Manual. * Due to continuing improvement, above specifications may be subject to change without notice.			

Notes :	Unit converter
1.Nominal cooling conditions Indoor:27°CDB/19°CWB(81°FDB/66°FWB), Outdoor:35°CDB(95°FDB) Pipe length:7.5m(24-9/16ft.), Level difference:0m(0ft.)	kcal =kW x 860 BTU/h =kW x 3,412
2.The values are measured at the rated external static pressure.	cfm =m ³ /min x 35.31
3.Nominal heating conditions Indoor:20°CDB(68°FDB), Outdoor:7°CDB/6°CWB(45°FDB/43°FWB) Pipe length:7.5m(24-9/16ft.), Level difference:0m(0ft.)	lbs =kg / 0.4536
4.The rated external static pressure is shown without < >.The factory setting is the rated value.	
	*Above specification data is subject to rounding variation.

1. SPECIFICATIONS

Model			PEFY-P50VMA-E	PEFY-P63VMA-E	PEFY-P80VMA-E		
Power source			1-phase 220-230-240V 50Hz	1-phase 220-230-240V 50Hz	1-phase 220-230-240V 50Hz		
Cooling capacity (Nominal)	*1	kW	5.6	7.1	9.0		
		kcal / h	4,800	6,100	7,700		
		BTU / h	19,100	24,200	30,700		
	*2	Power input	kW	0.11	0.12	0.14	
	*2	Current input	A	0.74	1.01	1.15	
Heating capacity (Nominal)	*3	kW	6.3	8.0	10.0		
		kcal / h	5,400	6,900	8,600		
		BTU / h	21,500	27,300	34,100		
	*2	Power input	kW	0.09	0.10	0.12	
	*2	Current input	A	0.63	0.90	1.04	
External finish			Galvanized steel plate	Galvanized steel plate	Galvanized steel plate		
External dimension HxWxD			mm	250 x 900 x 732	250 x 1,100 x 732		
			inch	9-7/8 x 35-7/16 x 28-7/8	9-7/8 x 43-5/16 x 28-7/8		
Net weight			kg(lbs)	26(58)	32(71)		
Heat exchanger			Cross fin(Aluminum fin and copper tube)	Cross fin(Aluminum fin and copper tube)	Cross fin(Aluminum fin and copper tube)		
FAN	Type x Quantity		Sirocco fan x 1	Sirocco fan x 2	Sirocco fan x 2		
	*4	External static press.	Pa	<35> - 50 - <70> - <100> - <150>	<35> - 50 - <70> - <100> - <150>	<35> - 50 - <70> - <100> - <150>	
			mmH ₂ O	<3.6> - 5.1 - <7.1> - <10.2> - <15.3>	<3.6> - 5.1 - <7.1> - <10.2> - <15.3>	<3.6> - 5.1 - <7.1> - <10.2> - <15.3>	
	Motor Type		DC brushless motor	DC brushless motor	DC brushless motor		
	Motor output		kW	0.085	0.121	0.121	
	Driving mechanism		Direct-driven by motor	Direct-driven by motor	Direct-driven by motor		
	Air flow rate		(Low-Mid-High)	(Low-Mid-High)	(Low-Mid-High)		
			m ³ / min	12.0 - 14.5 - 17.0	13.5 - 16.0 - 19.0	14.5 - 18.0 - 21.0	
			L/s	200 - 242 - 283	225 - 267 - 317	242 - 300 - 350	
			cfm	424 - 512 - 600	477 - 565 - 671	512 - 636 - 742	
Sound pressure level (measured in anechoic room)			(Low-Mid-High)	(Low-Mid-High)	(Low-Mid-High)		
			*2	dB <A>	25-29-32	25-29-33	26-29-34
Insulation material			EPS, Polyethylene foam, Urethane foam	EPS, Polyethylene foam, Urethane foam	EPS, Polyethylene foam, Urethane foam		
Air filter			PP honeycomb fabric.	PP honeycomb fabr	PP honeycomb fabric.		
Protection device			Fuse	Fuse	Fuse		
Refrigerant control device			LEV	LEV	LEV		
Connectable outdoor unit			R410A, R407C, R22 CITY MULTI	R410A, R407C, R22 CITY MULTI	R410A, R407C, R22 CITY MULTI		
Diameter of refrigerant pipe	Liquid (R410A) (R22, R407C)	mm(in.)	6.35(1/4)Braze	9.52(3/8)Braze	9.52(3/8)Braze		
			9.52(3/8)Braze	9.52(3/8)Braze	9.52(3/8)Braze		
	Gas (R410A) (R22, R407C)	mm(in.)	12.7(1/2)Braze	15.88(5/8)Braze	15.88(5/8)Braze		
			15.88(5/8)Braze	15.88(5/8)Braze	15.88(5/8)Braze		
Field drain pipe size			mm(in.)	O.D.32(1-1/4)	O.D.32(1-1/4)		
Drawing	External		IU-KB94-R528	IU-KB94-R528	IU-KB94-R528		
	Wiring		IU-KB94-R069	IU-KB94-R069	IU-KB94-R069		
	Refrigerant cycle		-	-	-		
Standard attachment	Document		Installation Manual, Instruction Book	Installation Manual, Instruction Book	Installation Manual, Instruction Book		
	Accessory		Insulation pipe for refrigerant pipe, Washer, Drain hose, Tie band	Insulation pipe for refrigerant pipe, Washer, Drain hose, Tie band	Insulation pipe for refrigerant pipe, Washer, Drain hose, Tie band		
Optional parts	Filter box		PAC-KE92TB-E	PAC-KE93TB-E	PAC-KE93TB-E		
Remarks			* Details on foundation work, duct work, insulation work, electrical wiring, power source switch, and other items shall be referred to the Installation Manual. * Due to continuing improvement, above specifications may be subject to change without notice.				

Notes :	1.Nominal cooling conditions Indoor:27°CDB/19°CWB(81°FDB/66°FWB), Outdoor:35°CDB(95°FDB) Pipe length:7.5m(24-9/16ft.), Level difference:0m(0ft.)	Unit converter kcal =kW x 860 BTU/h =kW x 3,412 cfm =m ³ /min x 35.31 lbs =kg / 0.4536
	2.The values are measured at the rated external static pressure.	
	3.Nominal heating conditions Indoor:20°CDB(68°FDB), Outdoor:7°CDB/6°CWB(45°FDB/43°FWB) Pipe length:7.5m(24-9/16ft.), Level difference:0m(0ft.)	
	4.The rated external static pressure is shown without < > .The factory setting is the rated value.	
		*Above specification data is subject to rounding variation.

1. SPECIFICATIONS

DATA G6

PEFY-VMA

Model			PEFY-P100VMA-E	PEFY-P125VMA-E	
Power source			1-phase 220-230-240V 50Hz	1-phase 220-230-240V 50Hz	
Cooling capacity (Nominal)	*1	kW	11.2	14.0	
	*1	kcal / h	9,600	12,000	
	*1	BTU / h	38,200	47,800	
	*2	Power input	kW	0.24	0.34
	*2	Current input	A	1.47	2.05
Heating capacity (Nominal)	*3	kW	12.5	16.0	
	*3	kcal / h	10,800	13,800	
	*3	BTU / h	42,700	54,600	
	*2	Power input	kW	0.22	0.32
	*2	Current input	A	1.36	1.94
External finish			Galvanized steel plate	Galvanized steel plate	
External dimension HxWxD		mm	250 x 1,400 x 732	250 x 1,400 x 732	
		inch	9-7/8 x 55-1/8 x 28-7/8	9-7/8 x 55-1/8 x 28-7/8	
Net weight		kg(lbs)	42(93)	42(93)	
Heat exchanger			Cross fin(Aluminum fin and copper tube)	Cross fin(Aluminum fin and copper tube)	
FAN	Type x Quantity		Sirocco fan x 2	Sirocco fan x 2	
	*4 External static press.	Pa	<35> - 50 - <70> - <100> - <150>	<35> - 50 - <70> - <100> - <150>	
		mmH ₂ O	<3.6> - 5.1 - <7.1> - <10.2> - <15.3>	<3.6> - 5.1 - <7.1> - <10.2> - <15.3>	
	Motor Type		DC brushless motor	DC brushless motor	
	Motor output	kW	0.244	0.244	
	Driving mechanism		Direct-driven by motor ^o	Direct-driven by motor	
	Air flow rate		(Low-Mid-High)	(Low-Mid-High)	
			m ³ / min	23.0 - 28.0 - 33.0	28.0 - 34.0 - 40.0
L/s			383 - 467 - 550	467 - 567 - 667	
	cfm	812 - 989 - 1,165	989 - 1,201 - 1,412		
Sound pressure level (measured in anechoic room)		(Low-Mid-High)	(Low-Mid-High)		
	*2	dB <A>	28-33-37	32-36-40	
Insulation material			EPS, Polyethylene foam, Urethane foam	EPS, Polyethylene foam, Urethane foam	
Air filter			PP honeycomb fabric.	PP honeycomb fabric.	
Protection device			Fuse	Fuse	
Refrigerant control device			LEV	LEV	
Connectable outdoor unit		*5	R410A, R407C, R22 CITY MULTI	R410A, R407C, R22 CITY MULTI	
Diameter of refrigerant pipe	Liquid (R410A) (R22, R407C)	mm(in.)	9.52(3/8)Braze	9.52(3/8)Braze	
			9.52(3/8)Braze	9.52(3/8)Braze	
	Gas (R410A) (R22, R407C)	mm(in.)	15.88(5/8)Braze	15.88(5/8)Braze	
			19.05(3/4)Braze	19.05(3/4)Braze	
Field drain pipe size		mm(in.)	O.D.32(1-1/4)	O.D.32(1-1/4)	
Drawing	External		IU-KB94-R528	IU-KB94-R528	
	Wiring		IU-KB94-R069	IU-KB94-R069	
	Refrigerant cycle		-	-	
Standard attachment	Document		Installation Manual, Instruction Book	Installation Manual, Instruction Book	
	Accessory		Insulation pipe for refrigerant pipe, Washer, Drain hose, Tie band	Insulation pipe for refrigerant pipe, Washer, Drain hose, Tie band	
Optional parts	Filter box		PAC-KE94TB-E	PAC-KE94TB-E	
Remarks			* Details on foundation work, duct work, insulation work, electrical wiring, power source switch, and other items shall be referred to the Installation Manual. * Due to continuing improvement, above specifications may be subject to change without notice.		

Notes :	Unit converter
1.Nominal cooling conditions Indoor:27°CDB/19°CWB(81°FDB/66°F WB), Outdoor:35°CDB(95°FDB) Pipe length:7.5m(24-9/16ft.), Level difference:0m(0ft.)	kcal =kW x 860
2.The values are measured at the rated external static pressure.	BTU/h =kW x 3,412
3.Nominal heating conditions Indoor:20°CDB(68°FDB), Outdoor:7°CDB/6°CWB(45°FDB/43°F WB) Pipe length:7.5m(24-9/16ft.), Level difference:0m(0ft.)	cfm =m ³ /min x 35.31
4.The rated external static pressure is shown without < >.The factory setting is the rated value.	lbs =kg / 0.4536
5.PEFY-P100,125VMA-E cannot be connected to PUMY-P100,125,140VHMB/YHMB. Connectable from June/2009 production. For further details, please contact your nearest sales office or distributor.	*Above specification data is subject to rounding variation.

PEFY-P20, 25, 32, 40, 50, 63, 80, 100, 125VMA-E

Unit : mm

- Note 1. Use M10 screw for the Suspension bolt (field supply).
- 2. Keep the service space for the maintenance at the bottom.
- 3. This chart indicates for PEFY-P63-80-100-125VMA-E models, which have 2 fans. PEFY-P20-25-32-40-50VMA-E models have 1 fan.
- 4. In case of the inlet duct, is used, remove the air filter (supply with the unit), then install the filter (field supply) at suction side.

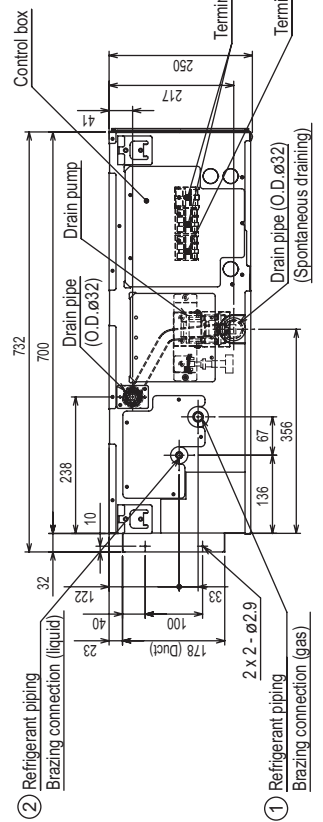
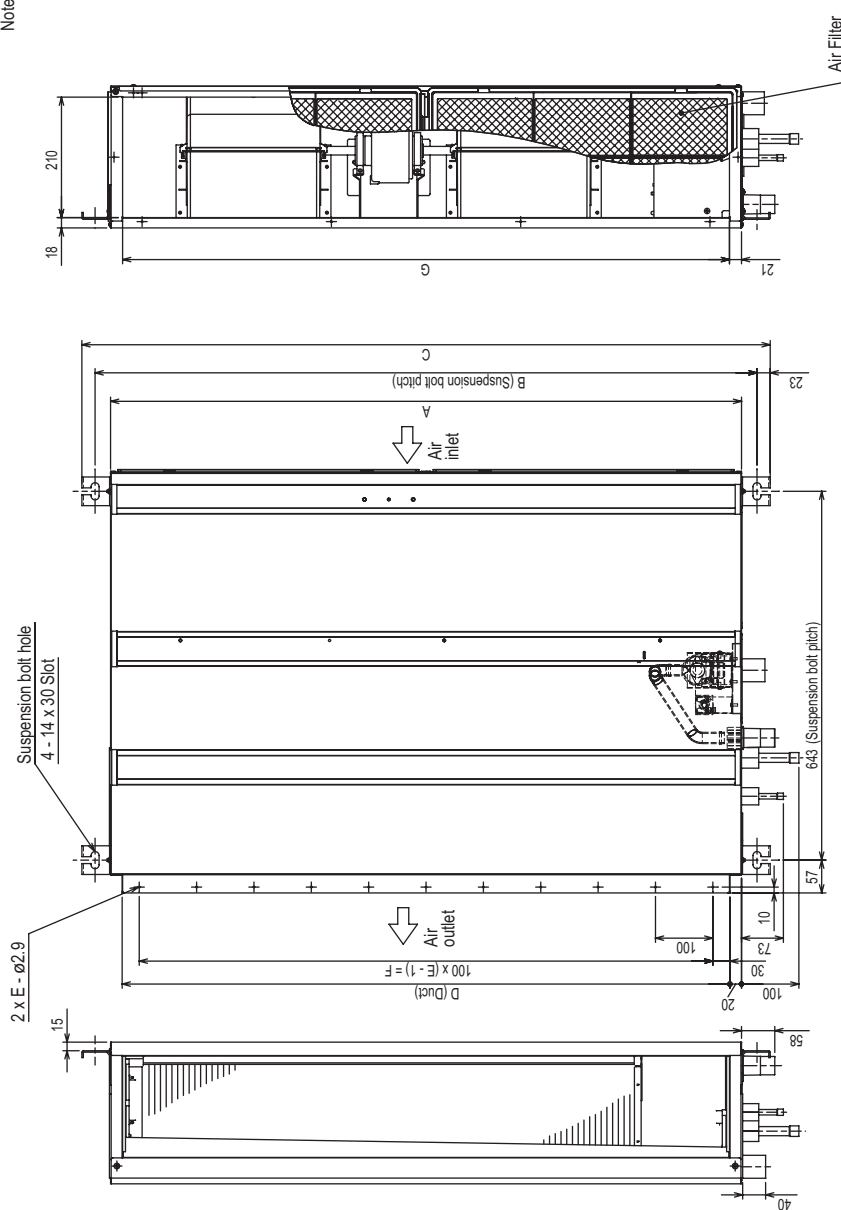

Model	A	B	C	D	E	F	G	① Gas pipe	② Liquid pipe
PEFY-P20,25,32VMA-E	700	754	800	660	7	600	658	ø12.7	ø6.35
PEFY-P40,50VMA-E	900	954	1000	860	9	800	858	ø15.88	ø9.52
PEFY-P63,80VMA-E	1100	1154	1200	1060	11	1000	1058		
PEFY-P100,125VMA-E	1400	1454	1500	1360	14	1300	1358		

2. EXTERNAL DIMENSIONS

DATA G6

PEFY-P20, 25, 32, 40, 50, 63, 80, 100, 125VMA-E

Unit : mm

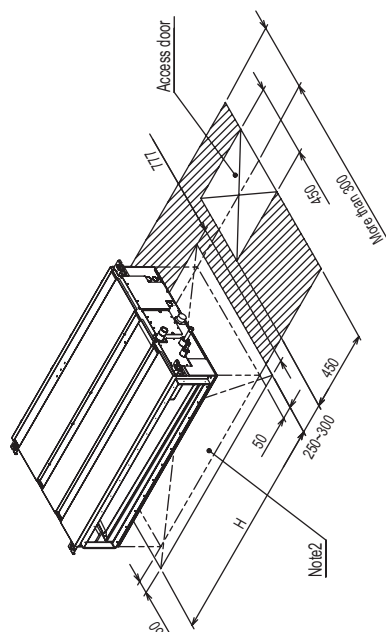
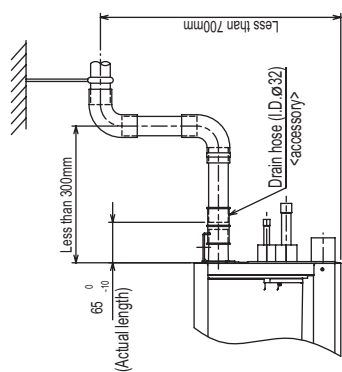

Required space for service and maintenance

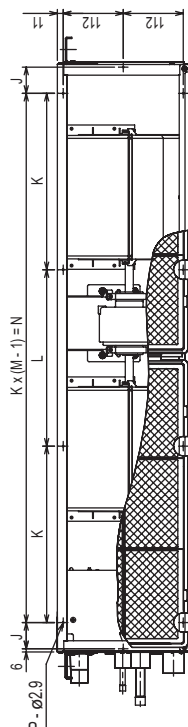

Model	H	J	K	L	M	N	P
PEFY-P20,25,32VMA-E	800	44	150	300			10
PEFY-P40VMA-E					4	780	10
PEFY-P60VMA-E	1000	54	260				
PEFY-P63,80VMA-E	1200	49	330		4	990	10
PEFY-P100,125VMA-E	1500	54	320		5	1280	12

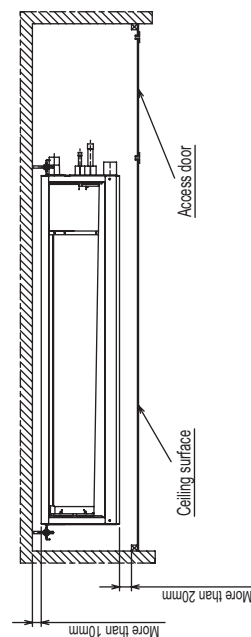

Make the access door at the appointed position properly for service maintenance.

2. EXTERNAL DIMENSIONS

DATA G6

PEFY-P20, 25, 32, 40, 50, 63, 80, 100, 125, VMA-E with filter box

Unit : mm

- Note 1. Use M10 screw for the Suspension bolt (field supply).
 2. Keep the service space for the maintenance at the bottom.
 3. This chart indicates for PEFY-P63-80-100-125VMA-E models, which have 2 fans. PEFY-P20-25-32-40-50VMA-E models have 1 fan.
 4. Use air filter installed with indoor unit.

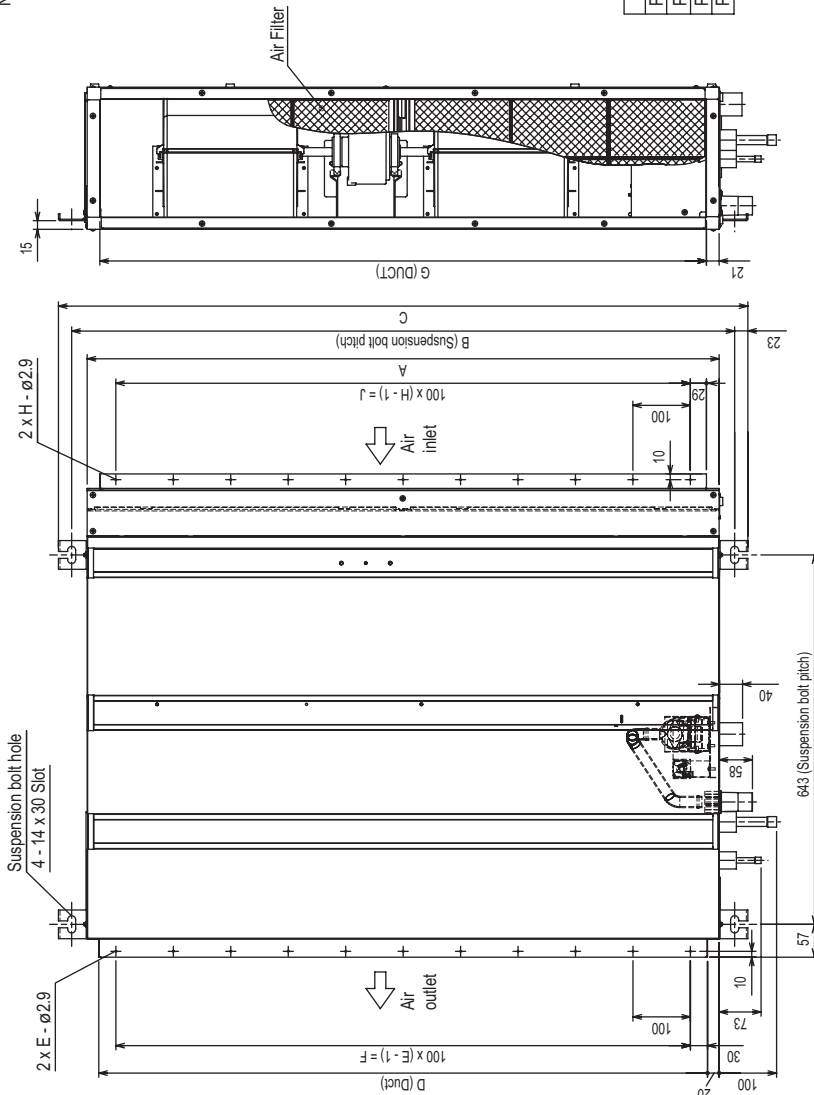

Model	① Gas pipe	② Liquid pipe	③ Filter box
PEFY-P20,25,32VMA-E	ø12.7	ø6.35	PAC-KE91TB-E
PEFY-P40,50VMA-E	ø15.88	ø9.52	PAC-KE92TB-E
PEFY-P63,80VMA-E			PAC-KE93TB-E
PEFY-P100,125VMA-E			PAC-KE94TB-E

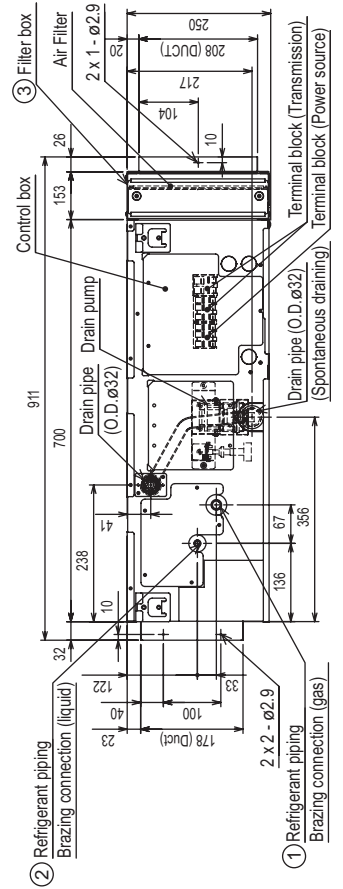

<Suction filter box built-in specification>

Model	A	B	C	D	E	G	H	F	J
PEFY-P20,25,32VMA-E	700	754	800	660	7	600	668	7	600
PEFY-P40,50VMA-E	900	954	1000	860	9	800	858	9	800
PEFY-P63,80VMA-E	1100	1154	1200	1060	11	1000	1058	11	1000
PEFY-P100,125VMA-E	1400	1454	1500	1360	14	1300	1358	14	1300

PEFY-P20, 25, 32, 40, 50, 63, 80, 100, 125VMA-E with filter box

Unit : mm

PEFY-VMA

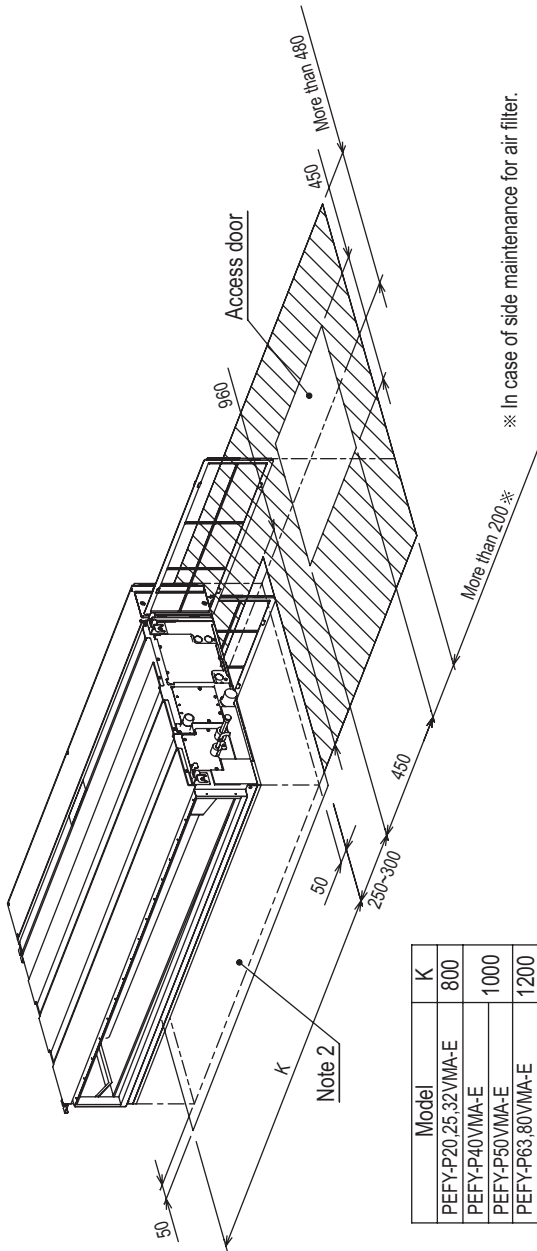
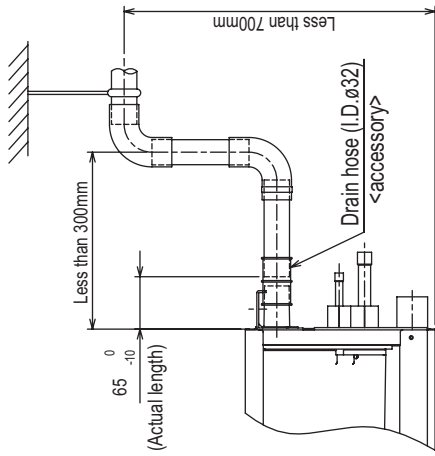

Required space for service and maintenance

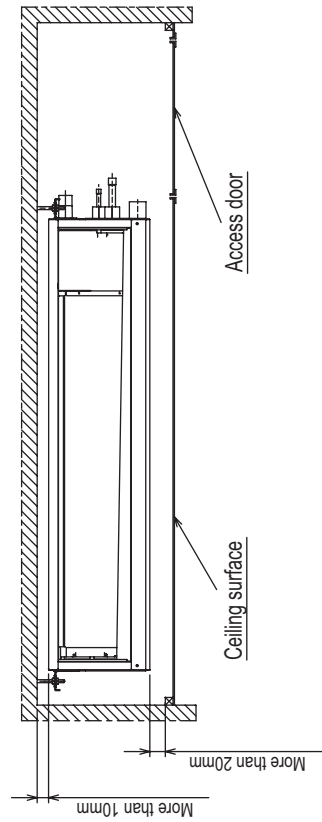

Make the access door at the appointed position properly for service maintenance.

PEFY-P20, 25, 32, 40, 50, 63, 80, 100, 125VMA-E

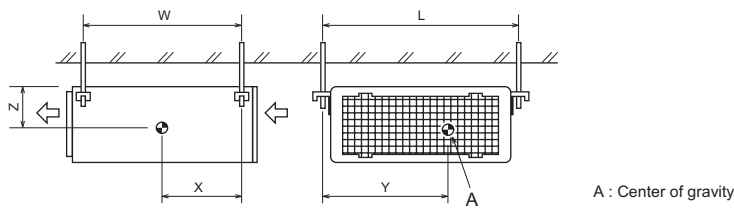

(mm)[in]

Model name	W	L	X	Y	Z
PEFY-P20VMA-E	643 [25 - 6/16]	754 [29 - 11/16]	330 [13]	300 [11 -13/16]	130 [5 -2/16]
PEFY-P25VMA-E	643 [25 - 6/16]	754 [29 - 11/16]	330 [13]	300 [11 -13/16]	130 [5 -2/16]
PEFY-P32VMA-E	643 [25 - 6/16]	754 [29 - 11/16]	330 [13]	300 [11 -13/16]	130 [5 -2/16]
PEFY-P40VMA-E	643 [25 - 6/16]	954 [37 - 9/16]	340 [13 - 7/16]	375 [14 -13/16]	130 [5 -2/16]
PEFY-P50VMA-E	643 [25 - 6/16]	954 [37 - 9/16]	340 [13 - 7/16]	375 [14 -13/16]	130 [5 -2/16]
PEFY-P63VMA-E	643 [25 - 6/16]	1154 [45 - 7/16]	325 [12 - 13/16]	525 [20 -11/16]	130 [5 -2/16]
PEFY-P80VMA-E	643 [25 - 6/16]	1154 [45 - 7/16]	325 [12 - 13/16]	525 [20 -11/16]	130 [5 -2/16]
PEFY-P100VMA-E	643 [25 - 6/16]	1454 [57 - 4/16]	330 [13]	675 [26 -10/16]	130 [5 -2/16]
PEFY-P125VMA-E	643 [25 - 6/16]	1454 [57 - 4/16]	330 [13]	675 [26 -10/16]	130 [5 -2/16]

PEFY-P20, 25, 32, 40, 50, 63, 80, 100, 125VMA-E

PEFY-VMA

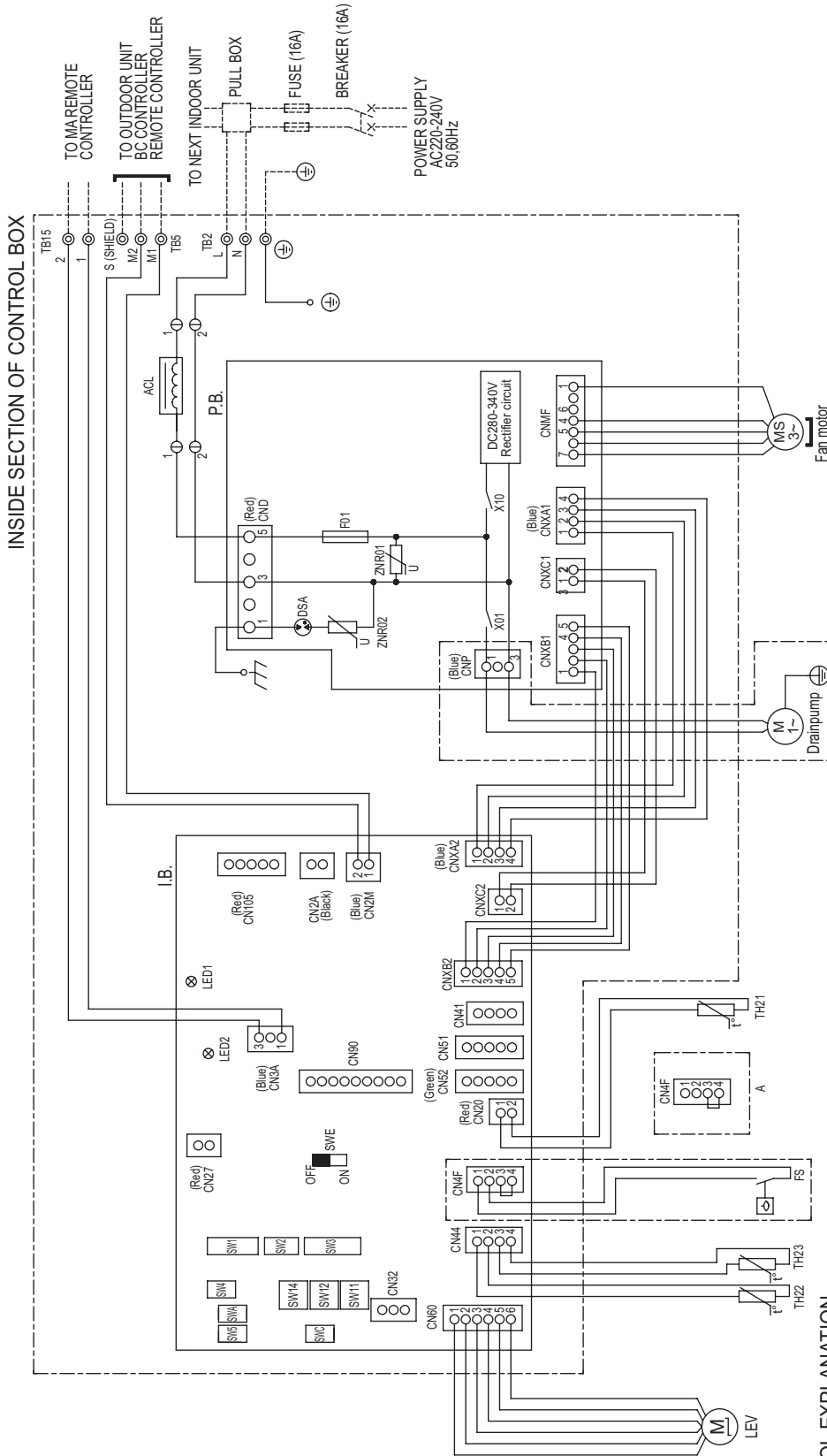

NOTE: 1. The wirings to TB2, TB5, TB15 shown in dotted line are field work.
 2. Mark ⊕ indicates terminal block, ⊙ connector.

SYMBOL EXPLANATION

SYMBOL	NAME	SYMBOL	NAME	SYMBOL	NAME
I.B.	Indoor controller board	CN41	Connector (HA terminal-A)	SW4 (I.B.)	Switch (for model selection)
P.B.	Power supply board	CN51	Connector (Centrally control)	SW5 (I.B.)	Switch (for mode selection)
TB2	Power source terminal block	CN52	Connector (Remote indication)	SW11 (I.B.)	Switch (1's digit address set)
TB5	Transmission terminal block	CN90	Connector (Wireless)	SW12 (I.B.)	Switch (10ths digit address set)
TB15	Transmission terminal block	CN105	Connector (IT terminal)	SW14 (I.B.)	Switch (BRANCH No.)
F01	Fuse AC250V 6.3A	CN2A	Connector (0-10V Analog input)	SWA (I.B.)	Switch (for static pressure selection)
ZNR01,02	Varistor	FS	Fuse	SWC (I.B.)	Switch (for static pressure selection)
DSA	Arrester	TH21	Thermistor (inlet air temp. detection)	SWE (I.B.)	Connector (emergency operation)
X01	Aux. relay	TH22	Thermistor (piping temp. detection/liquid)	LED1	LED (Power supply)
X10	Aux. relay	TH23	Thermistor (piping temp. detection/gas)	LED2	LED (Remote controller supply)
ACL	AC reactor (Power factor improvement)	SW1 (I.B.)	Switch (for mode selection)		
CN27	Connector (Dampner)	SW2 (I.B.)	Switch (for capacity code)		
CN32	Connector (Remote switch)	SW3 (I.B.)	Switch (for mode selection)		

5-1. Sound levels

Ceiling suspended

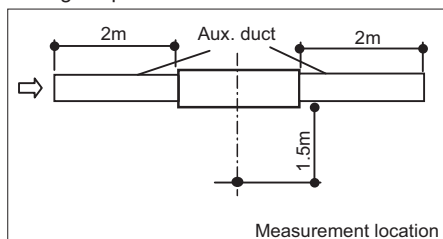

* Measured in anechoic room.

Sound level at anechoic room : Low-Mid-High

Model	Sound level dB(A)				
	35Pa	50Pa	70Pa	100Pa	150Pa
PEFY-P20VMA-E	23-24-25	23-25-26	23-26-28	24-27-30	25-30-34
PEFY-P25VMA-E	23-24-25	23-25-26	23-26-28	24-27-30	25-30-34
PEFY-P32VMA-E	23-25-28	23-26-29	24-27-30	25-28-32	28-32-36
PEFY-P40VMA-E	23-26-29	23-27-30	24-28-31	26-29-33	29-33-37
PEFY-P50VMA-E	24-28-31	25-29-32	26-30-33	27-31-34	29-34-38
PEFY-P63VMA-E	25-28-32	25-29-33	26-30-34	27-31-35	29-34-38
PEFY-P80VMA-E	26-29-33	26-29-34	26-30-35	29-33-37	32-37-41
PEFY-P100VMA-E	28-32-36	28-33-37	30-35-39	31-36-40	33-38-43
PEFY-P125VMA-E	31-35-39	32-36-40	32-37-41	33-39-42	37-40-44

PEFY-VMA

5-2. NC curves

PEFY-P20,25VMA-E

External Static Pressure: 35Pa
Power Source: 220-230-240V, 50Hz

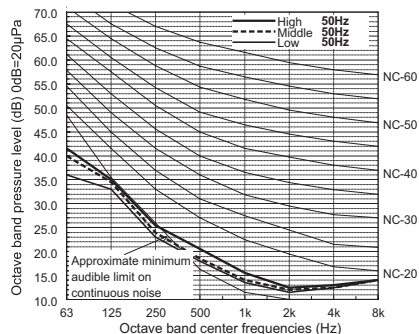

PEFY-P20,25VMA-E

External Static Pressure: 50Pa
Power Source: 220-230-240V, 50Hz

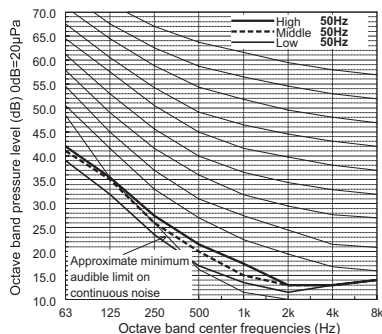

PEFY-P20,25VMA-E

External Static Pressure: 70Pa
Power Source: 220-230-240V, 50Hz

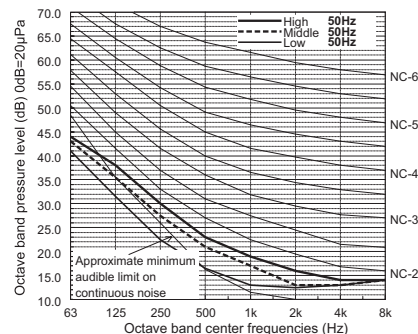

PEFY-P20,25VMA-E

External Static Pressure: 100Pa
Power Source: 220-230-240V, 50Hz

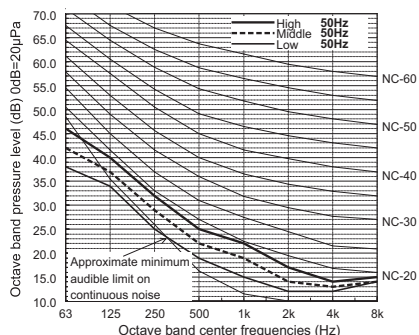

PEFY-P20,25VMA-E

External Static Pressure: 150Pa
Power Source: 220-230-240V, 50Hz

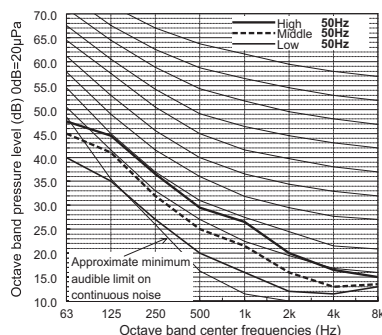

PEFY-P32VMA-E

External Static Pressure: 35Pa
Power Source: 220-230-240V, 50Hz

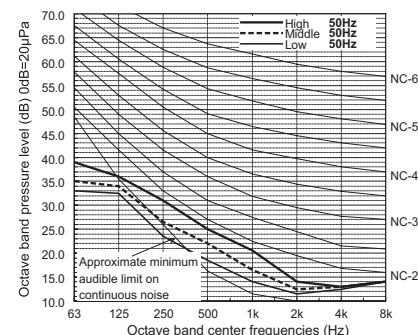

PEFY-VMA

PEFY-P32VMA-E

External Static Pressure: 50Pa
Power Source: 220-230-240V, 50Hz

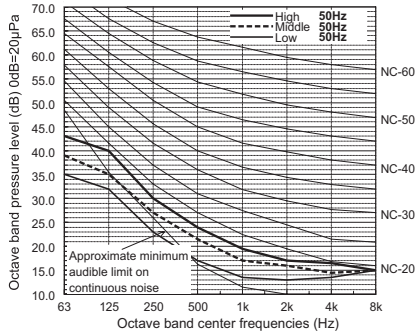

PEFY-P32VMA-E

External Static Pressure: 70Pa
Power Source: 220-230-240V, 50Hz

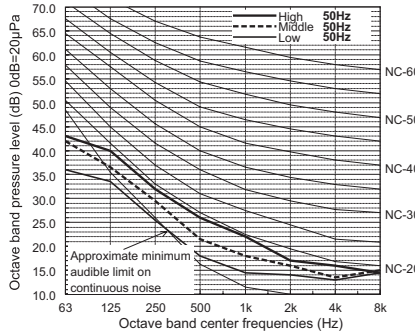

PEFY-P32VMA-E

External Static Pressure: 100Pa
Power Source: 220-230-240V, 50Hz

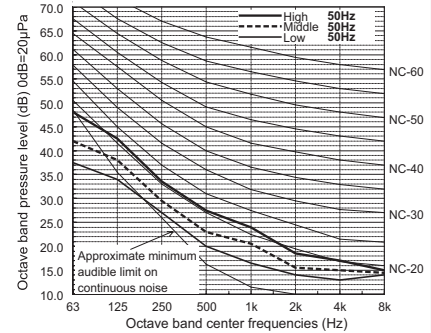

PEFY-P32VMA-E

External Static Pressure: 150Pa
Power Source: 220-230-240V, 50Hz

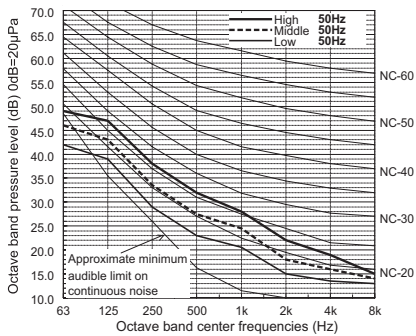

PEFY-P40VMA-E

External Static Pressure: 35Pa
Power Source: 220-230-240V, 50Hz

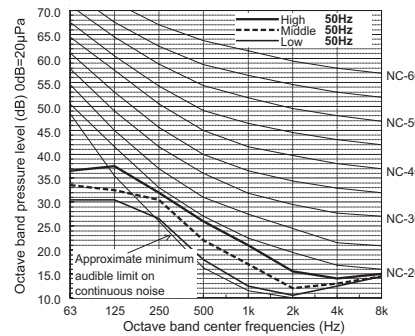

PEFY-P40VMA-E

External Static Pressure: 50Pa
Power Source: 220-230-240V, 50Hz

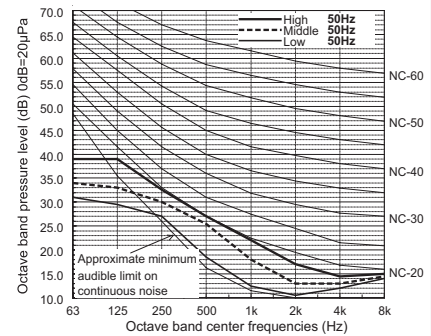

PEFY-P40VMA-E

External Static Pressure: 70Pa
Power Source: 220-230-240V, 50Hz

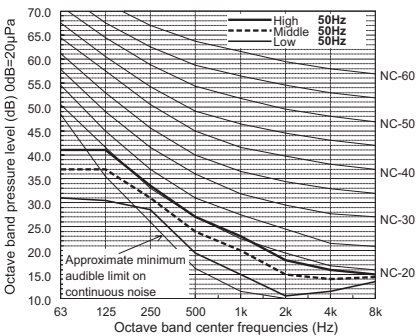

PEFY-P40VMA-E

External Static Pressure: 100Pa
Power Source: 220-230-240V, 50Hz

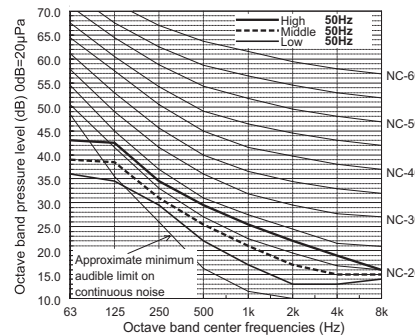

PEFY-P40VMA-E

External Static Pressure: 150Pa
Power Source: 220-230-240V, 50Hz

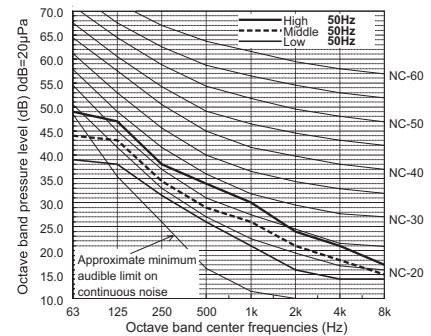

PEFY-P50VMA-E

External Static Pressure: 35Pa
Power Source: 220-230-240V, 50Hz

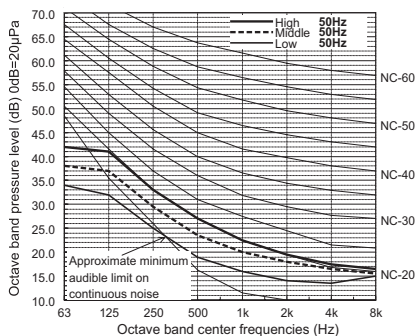

PEFY-P50VMA-E

External Static Pressure: 50Pa
Power Source: 220-230-240V, 50Hz

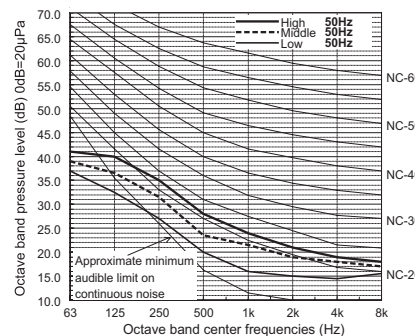

PEFY-P50VMA-E

External Static Pressure: 70Pa
Power Source: 220-230-240V, 50Hz

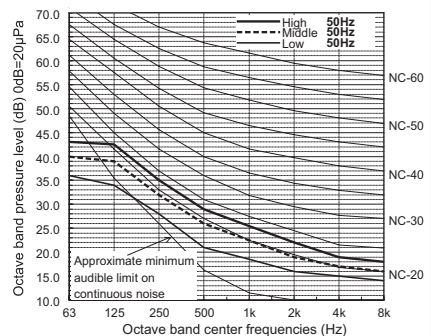

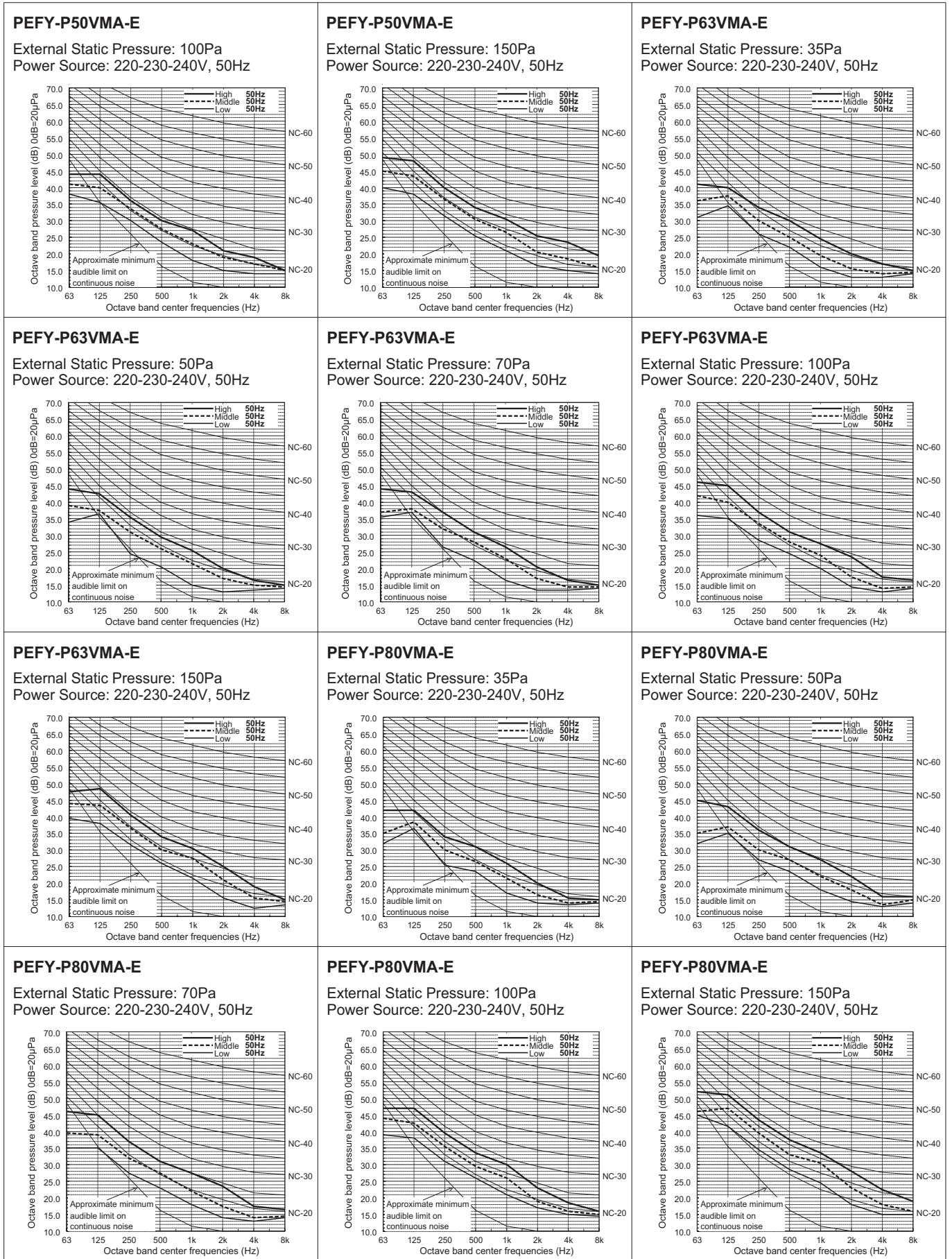

PEFY-VMA

PEFY-P100VMA-E

External Static Pressure: 35Pa
Power Source: 220-230-240V, 50Hz

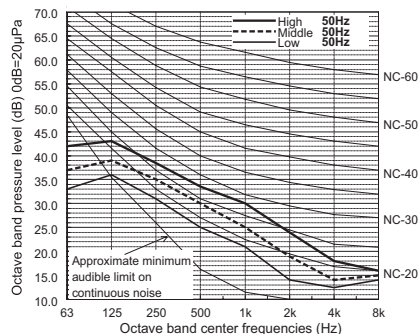

PEFY-P100VMA-E

External Static Pressure: 50Pa
Power Source: 220-230-240V, 50Hz

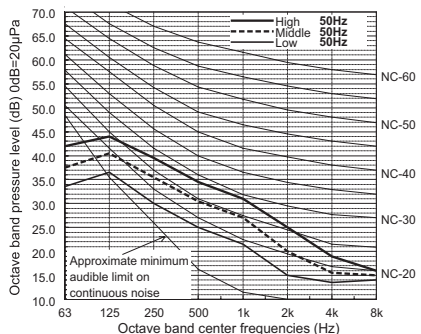

PEFY-P100VMA-E

External Static Pressure: 70Pa
Power Source: 220-230-240V, 50Hz

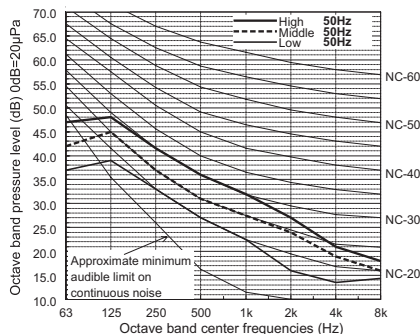

PEFY-P100VMA-E

External Static Pressure: 100Pa
Power Source: 220-230-240V, 50Hz

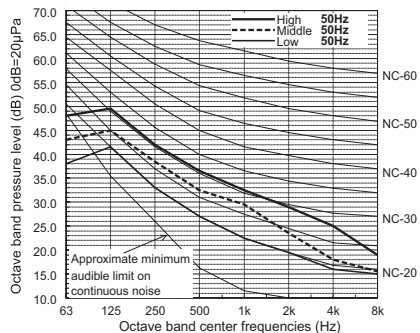

PEFY-P100VMA-E

External Static Pressure: 150Pa
Power Source: 220-230-240V, 50Hz

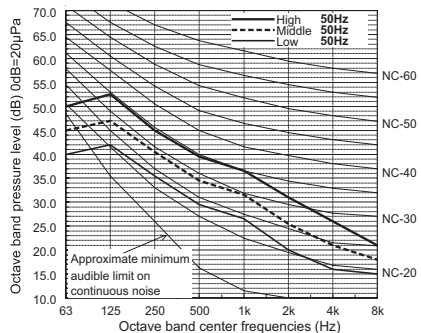

PEFY-P125VMA-E

External Static Pressure: 35Pa
Power Source: 220-230-240V, 50Hz

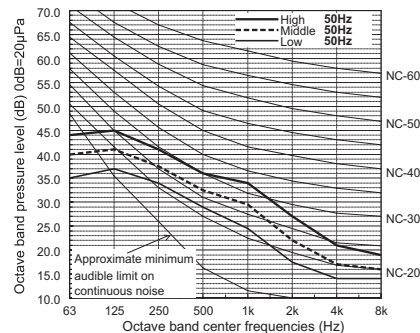

PEFY-P125VMA-E

External Static Pressure: 50Pa
Power Source: 220-230-240V, 50Hz

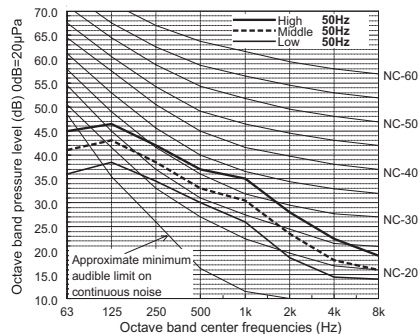

PEFY-P125VMA-E

External Static Pressure: 70Pa
Power Source: 220-230-240V, 50Hz

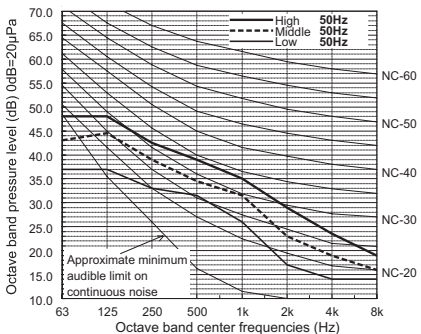

PEFY-P125VMA-E

External Static Pressure: 100Pa
Power Source: 220-230-240V, 50Hz

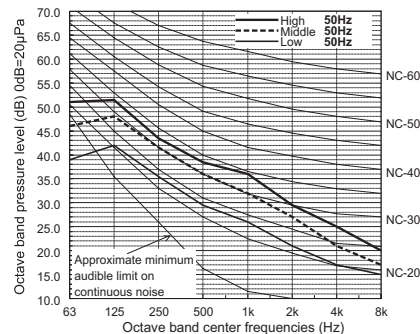

PEFY-P125VMA-E

External Static Pressure: 150Pa
Power Source: 220-230-240V, 50Hz

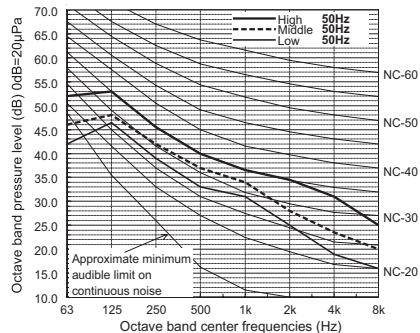

6. FAN CHARACTERISTICS CURVES

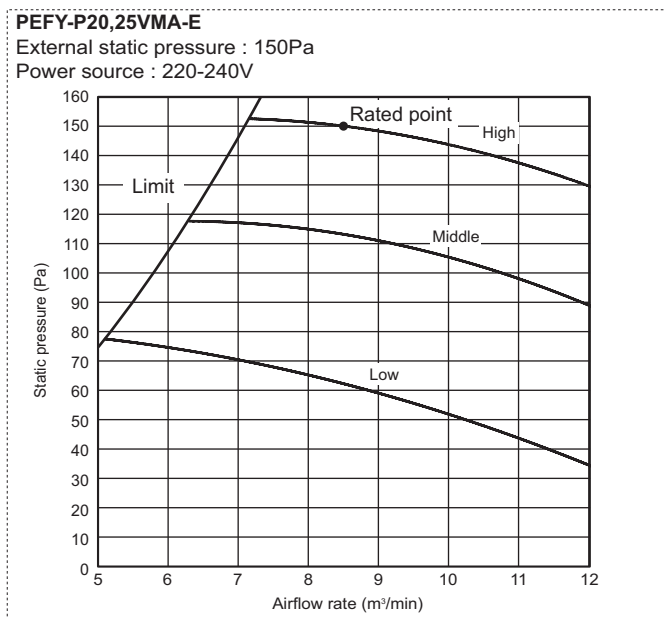
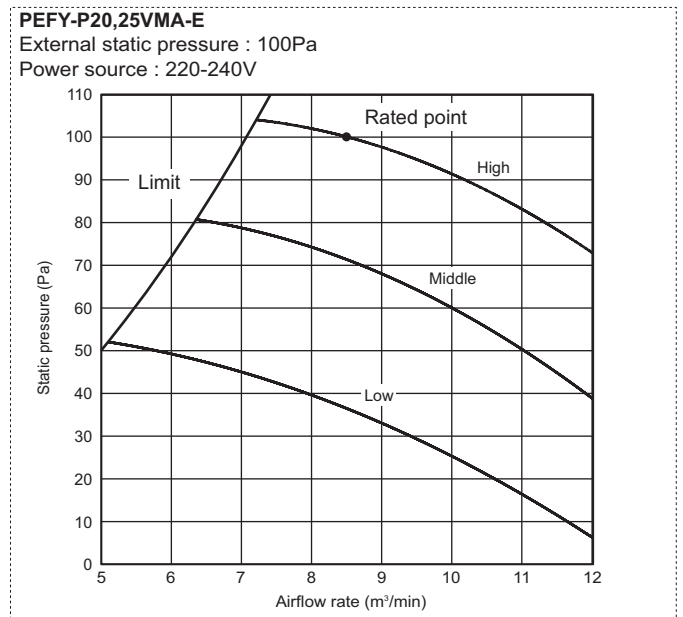
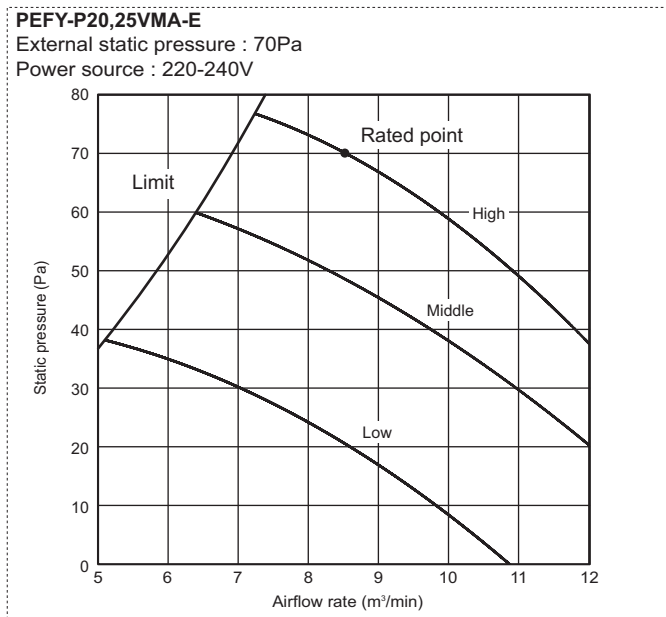
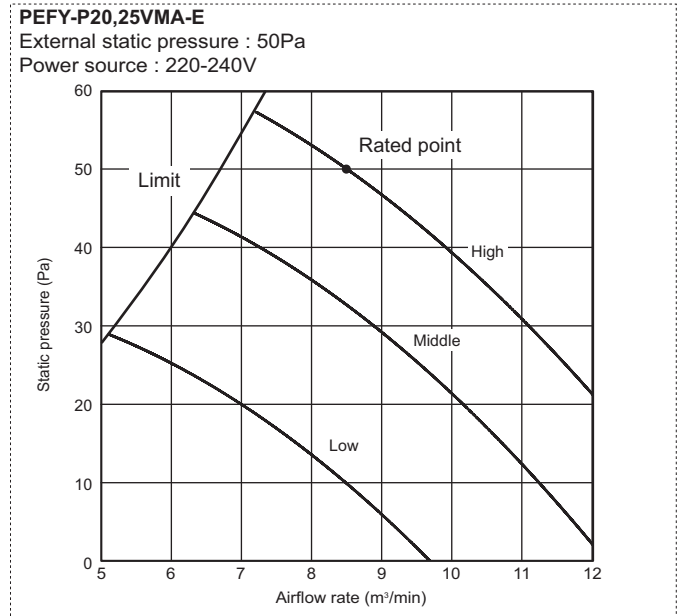
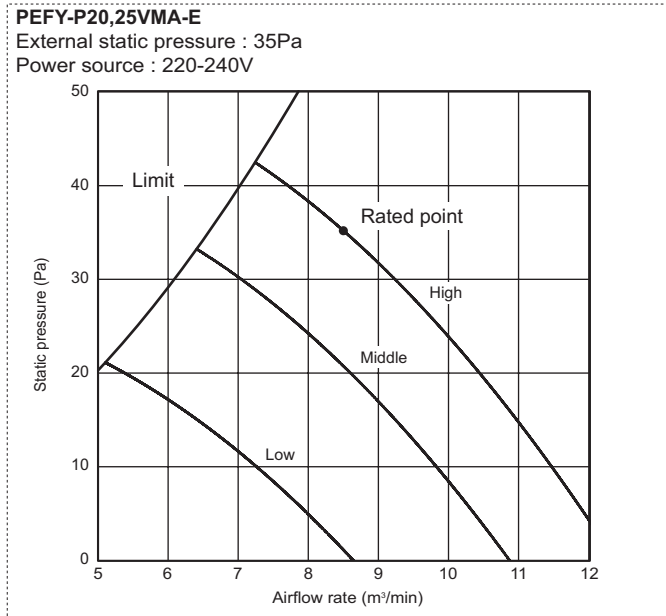

PEFY-VMA

6. FAN CHARACTERISTICS CURVES

PEFY-VMA

PEFY-P32VMA-E

External static pressure : 35Pa
Power source : 220-240V

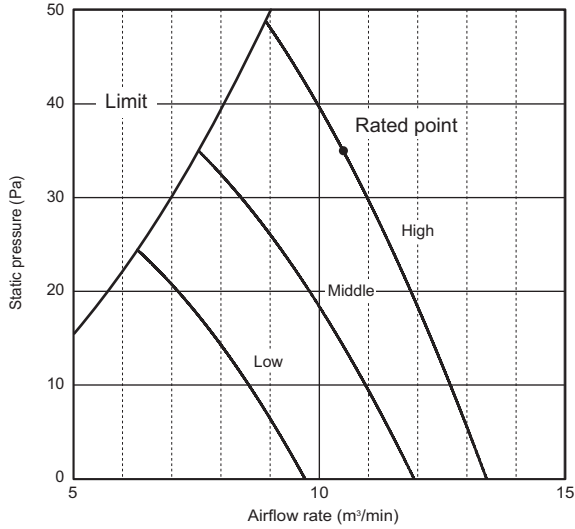

PEFY-P32VMA-E

External static pressure : 50Pa
Power source : 220-240V

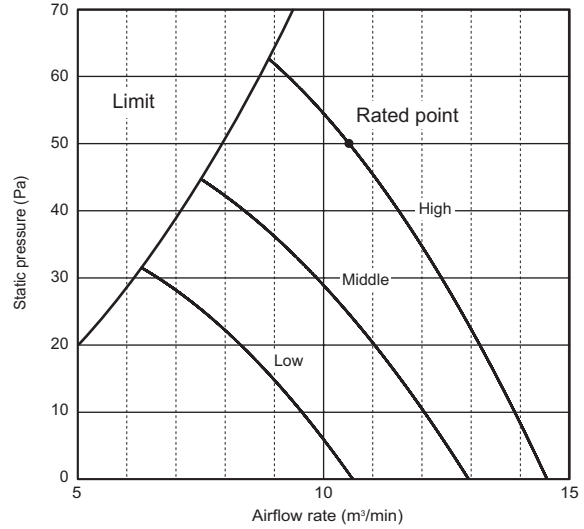

PEFY-P32VMA-E

External static pressure : 70Pa
Power source : 220-240V

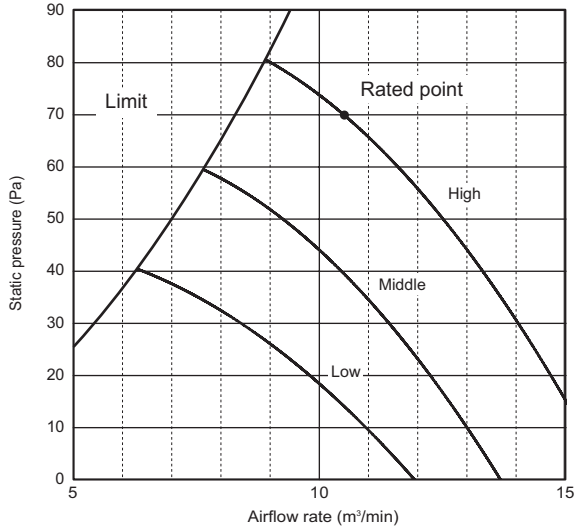

PEFY-P32VMA-E

External static pressure : 100Pa
Power source : 220-240V

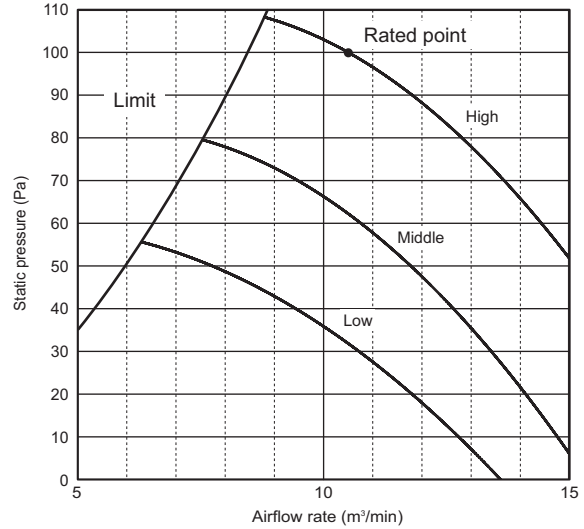

PEFY-P32VMA-E

External static pressure : 150Pa
Power source : 220-240V

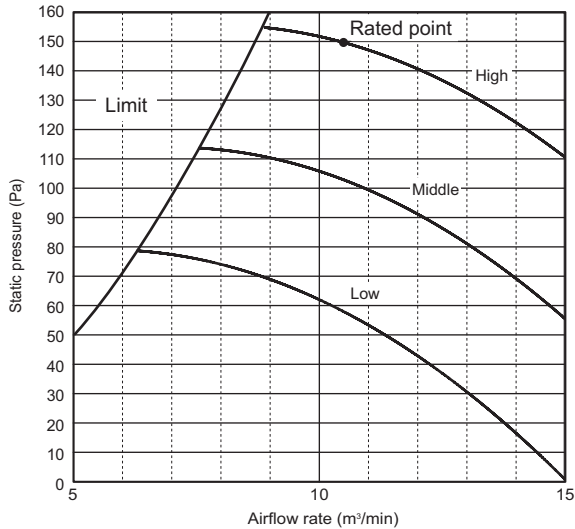

6. FAN CHARACTERISTICS CURVES

PEFY-P40VMA-E

External static pressure : 35Pa
Power source : 220-240V

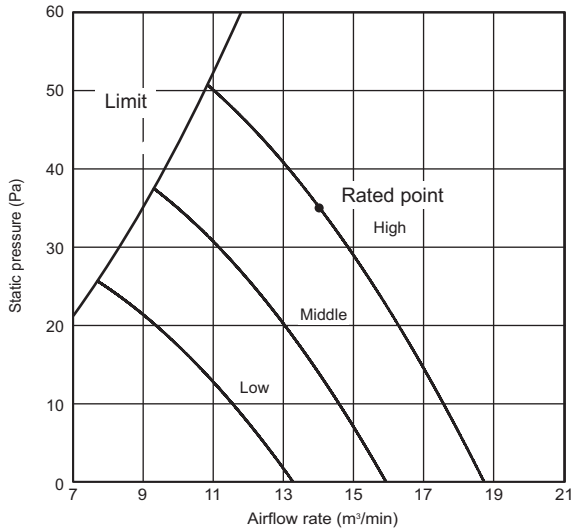

PEFY-P40VMA-E

External static pressure : 50Pa
Power source : 220-240V

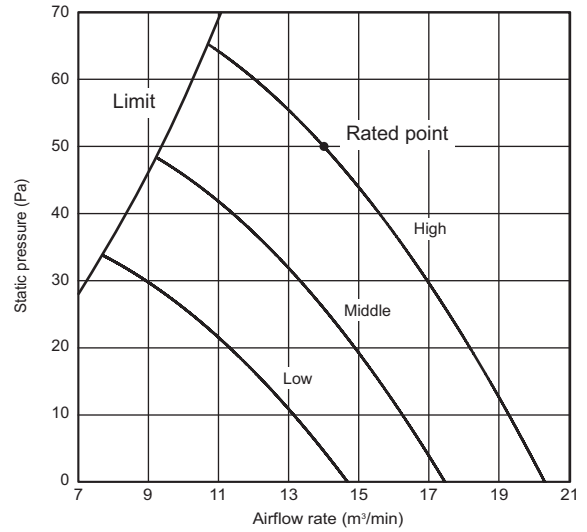

PEFY-P40VMA-E

External static pressure : 70Pa
Power source : 220-240V

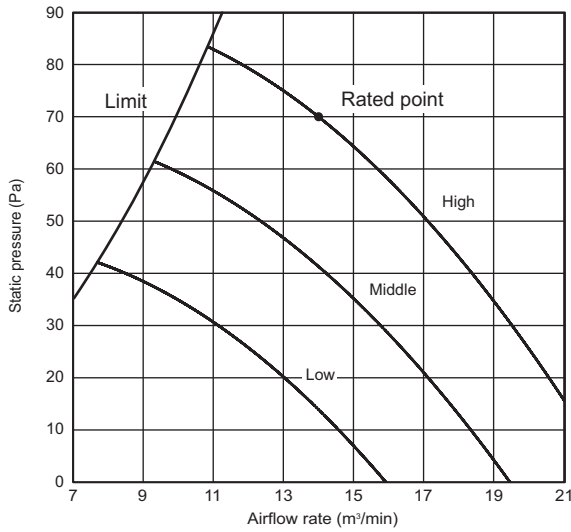

PEFY-P40VMA-E

External static pressure : 100Pa
Power source : 220-240V

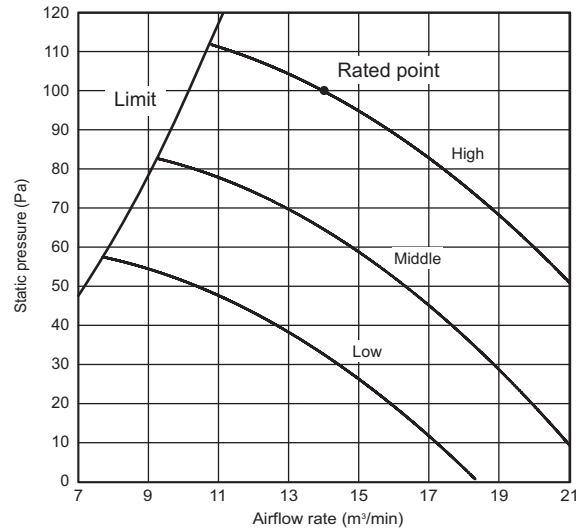

PEFY-P40VMA-E

External static pressure : 150Pa
Power source : 220-240V

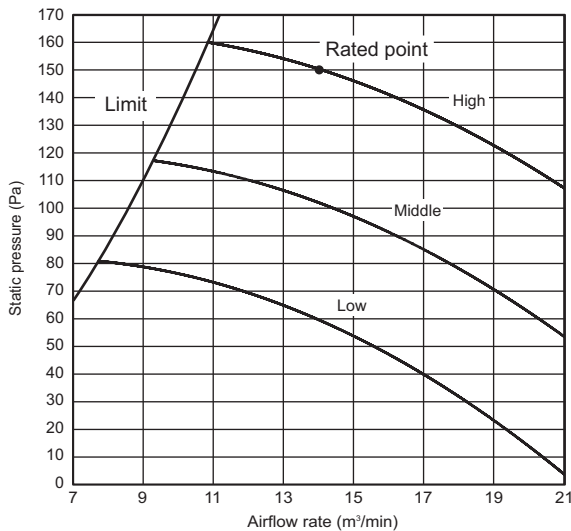

6. FAN CHARACTERISTICS CURVES

PEFY-VMA

PEFY-P50VMA-E

External static pressure : 35Pa
Power source : 220-240V

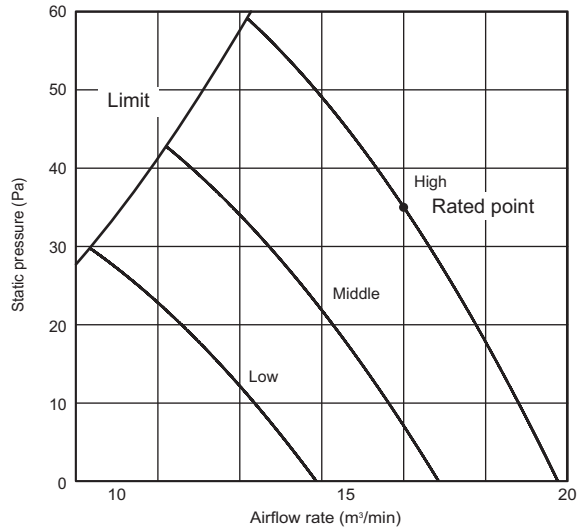

PEFY-P50VMA-E

External static pressure : 50Pa
Power source : 220-240V

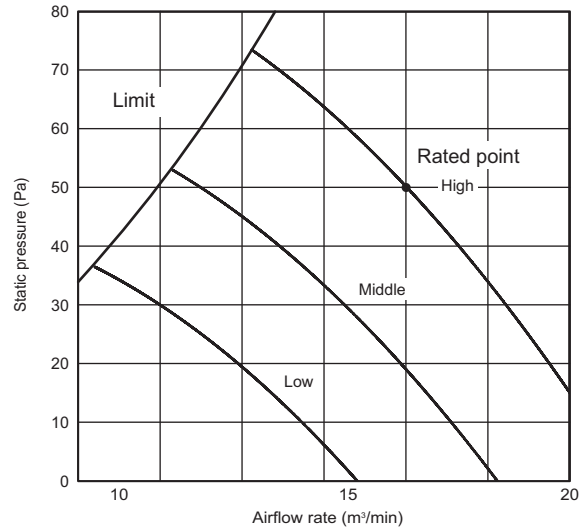

PEFY-P50VMA-E

External static pressure : 70Pa
Power source : 220-240V

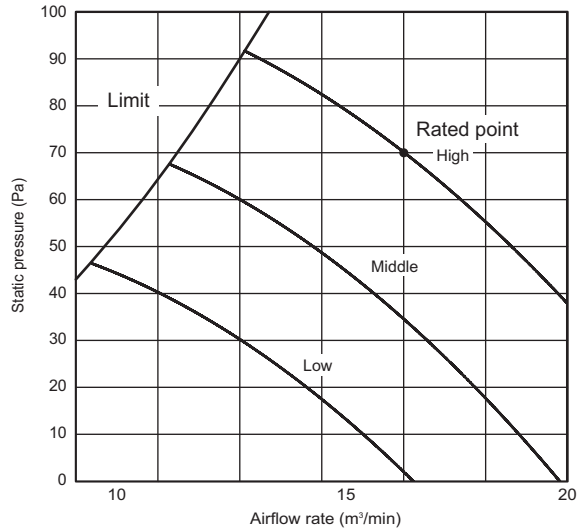

PEFY-P50VMA-E

External static pressure : 100Pa
Power source : 220-240V

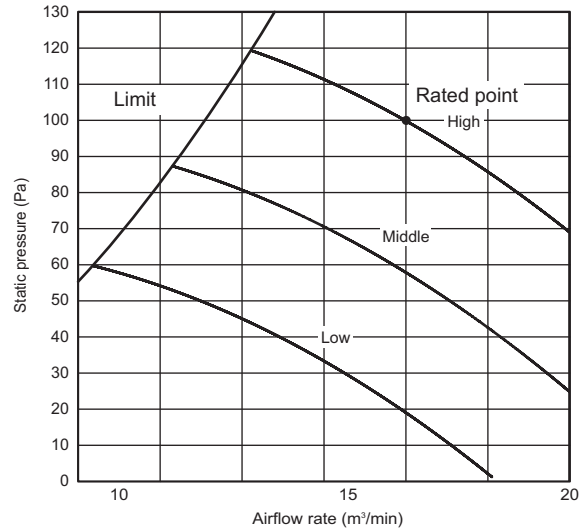

PEFY-P50VMA-E

External static pressure : 150Pa
Power source : 220-240V

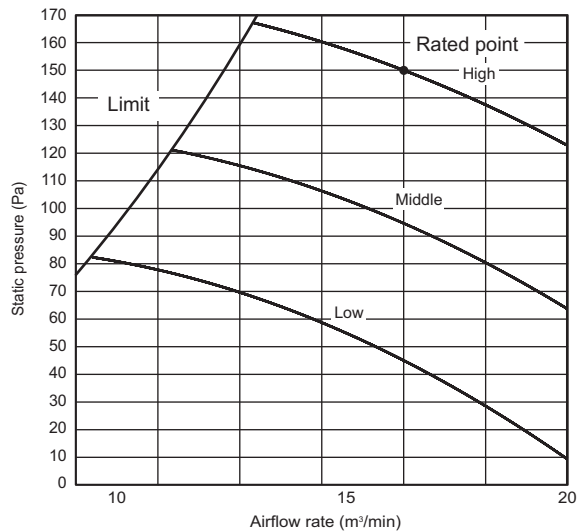

6. FAN CHARACTERISTICS CURVES

PEFY-P63VMA-E

External static pressure : 35Pa
Power source : 220-240V

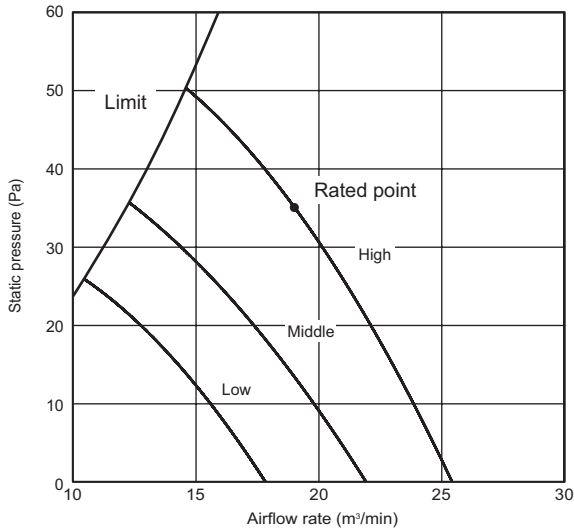

PEFY-P63VMA-E

External static pressure : 50Pa
Power source : 220-240V

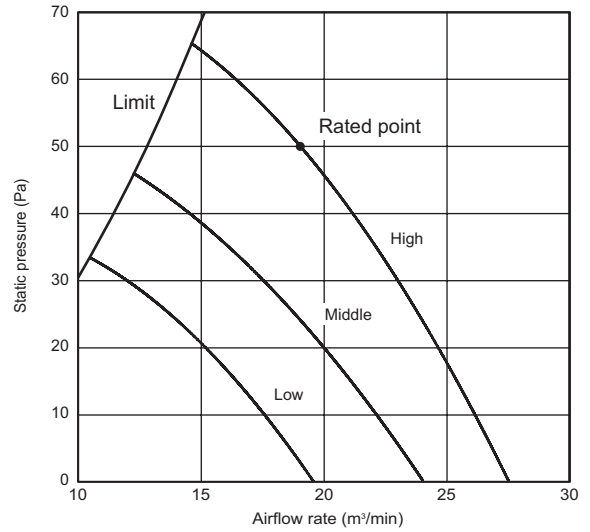

PEFY-P63VMA-E

External static pressure : 70Pa
Power source : 220-240V

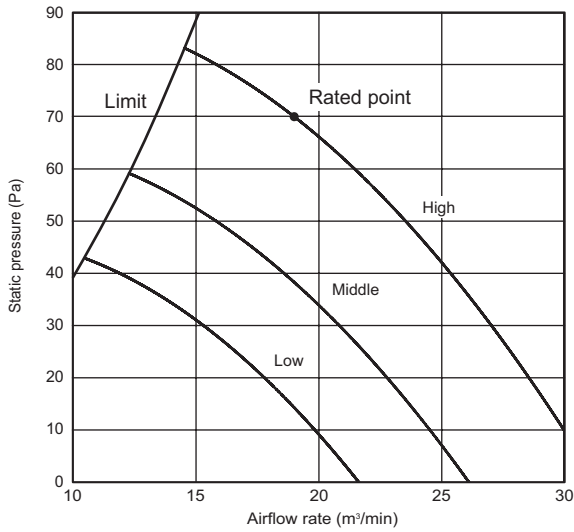

PEFY-P63VMA-E

External static pressure : 100Pa
Power source : 220-240V

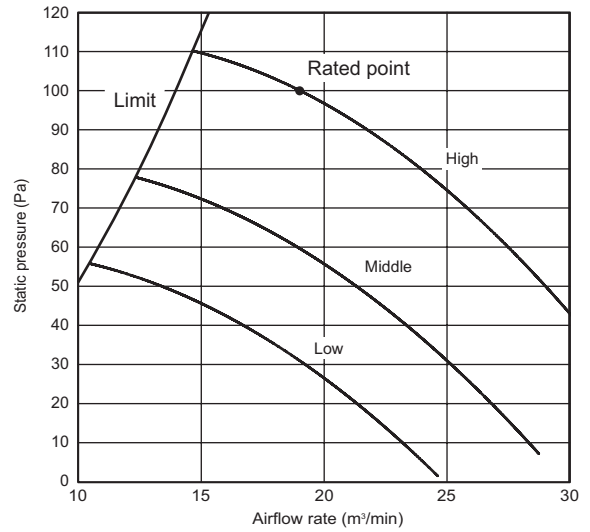

PEFY-P63VMA-E

External static pressure : 150Pa
Power source : 220-240V

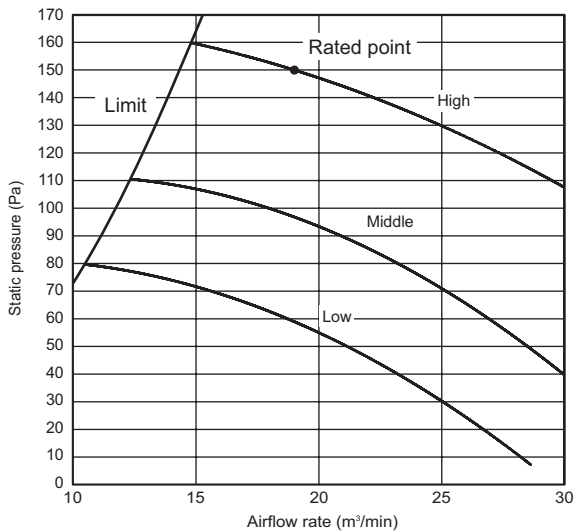

6. FAN CHARACTERISTICS CURVES

PEFY-VMA

PEFY-P80VMA-E

External static pressure : 35Pa
Power source : 220-240V

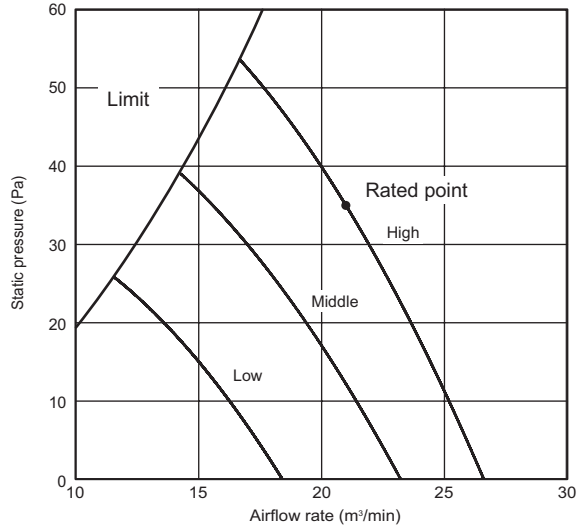

PEFY-P80VMA-E

External static pressure : 50Pa
Power source : 220-240V

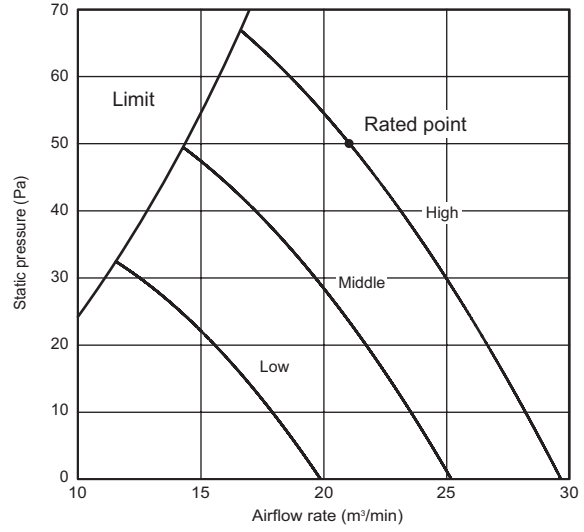

PEFY-P80VMA-E

External static pressure : 70Pa
Power source : 220-240V

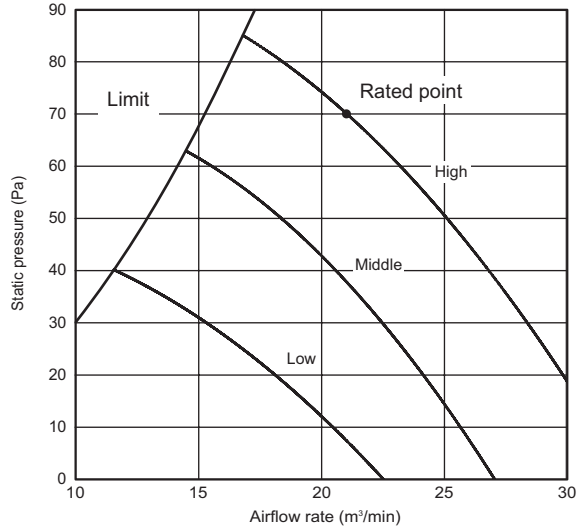

PEFY-P80VMA-E

External static pressure : 100Pa
Power source : 220-240V

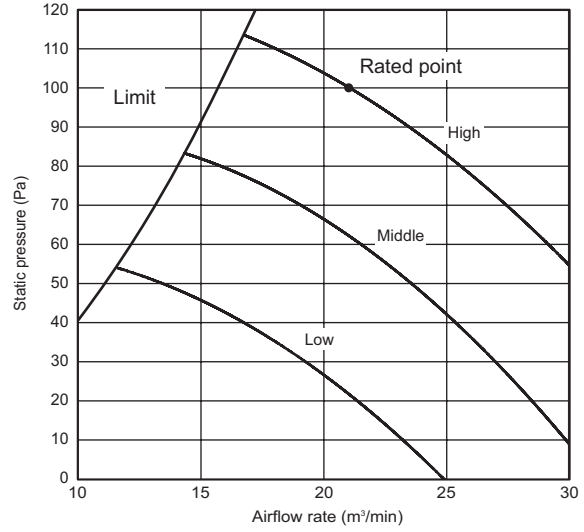

PEFY-P80VMA-E

External static pressure : 150Pa
Power source : 220-240V

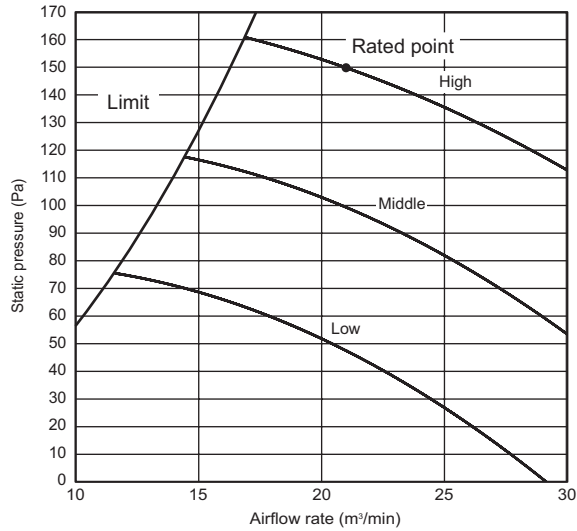

6. FAN CHARACTERISTICS CURVES

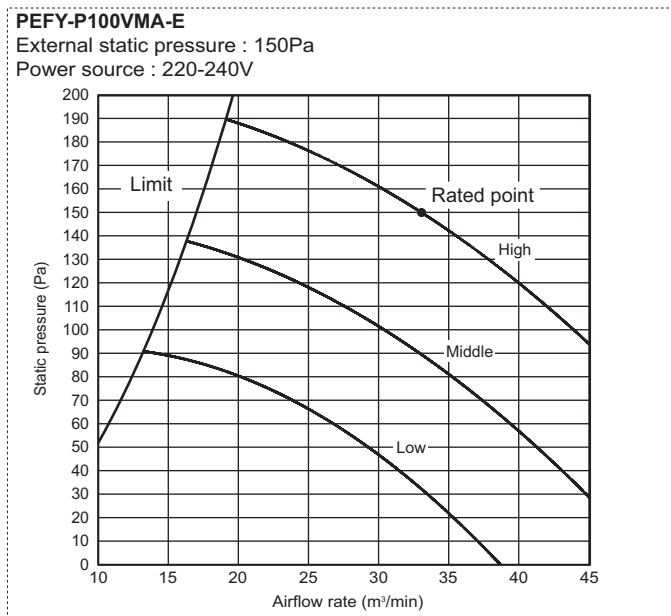
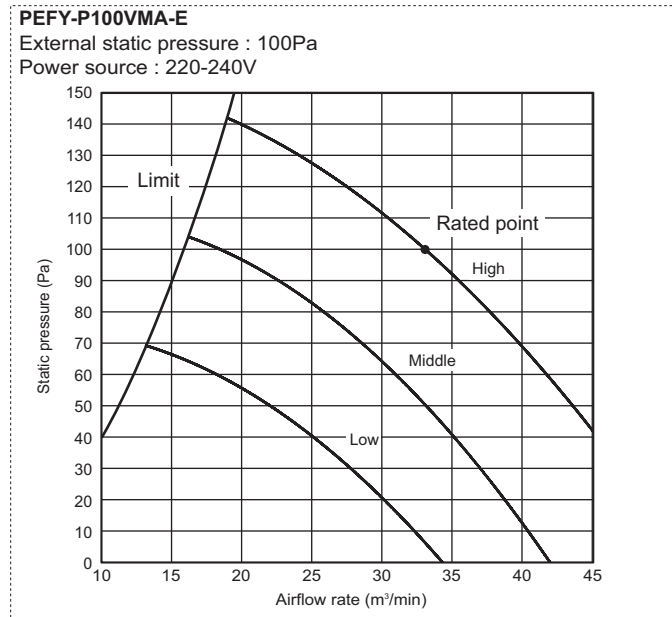
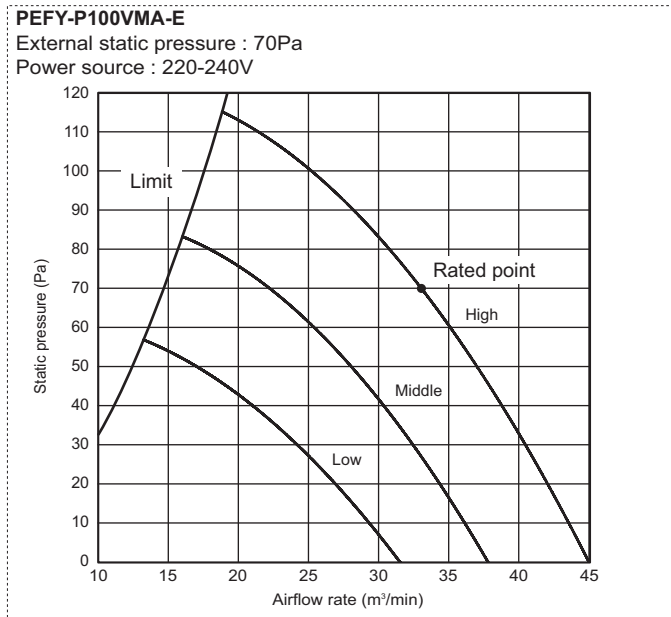
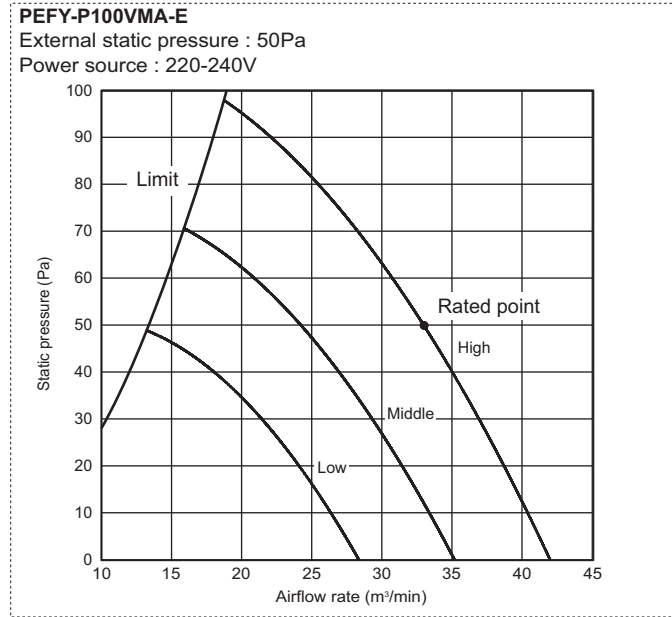
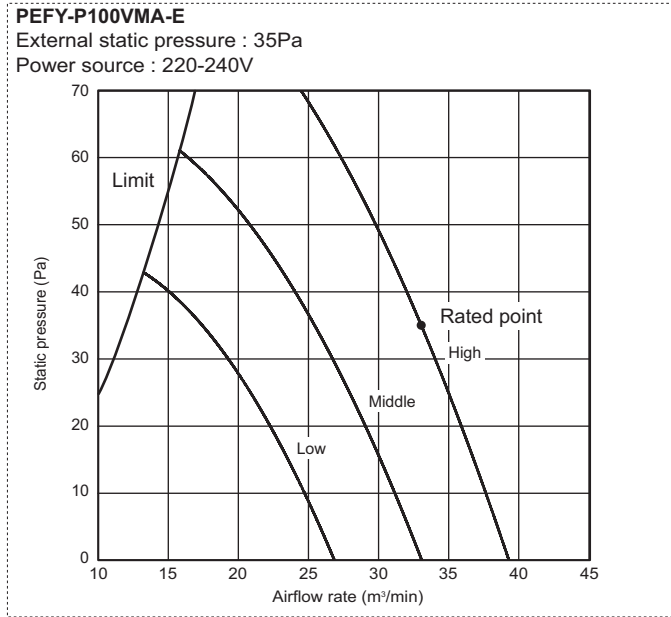

6. FAN CHARACTERISTICS CURVES

PEFY-VMA

PEFY-P125VMA-E

External static pressure : 35Pa
Power source : 220-240V

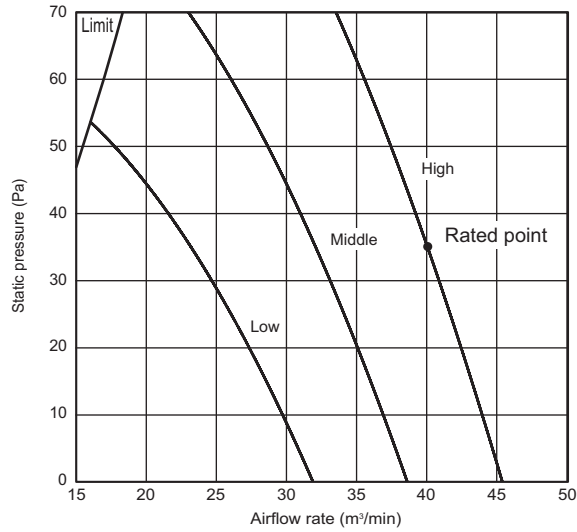

PEFY-P125VMA-E

External static pressure : 50Pa
Power source : 220-240V

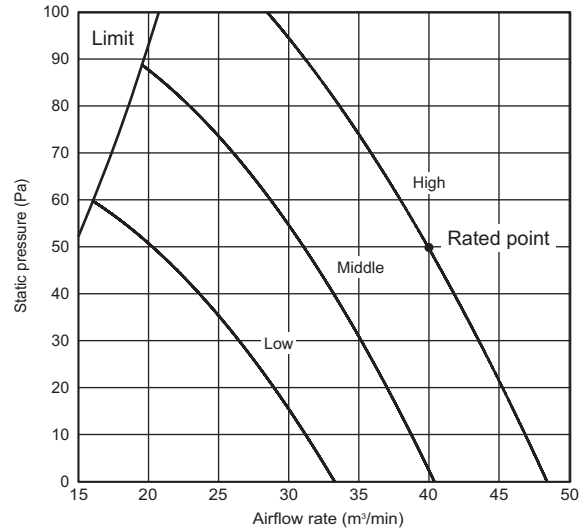

PEFY-P125VMA-E

External static pressure : 70Pa
Power source : 220-240V

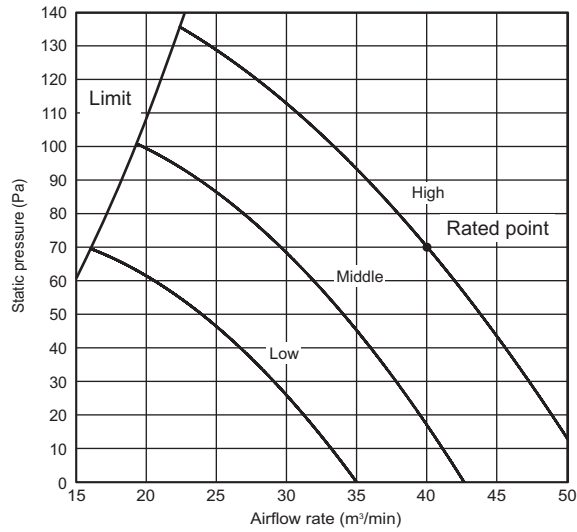

PEFY-P125VMA-E

External static pressure : 100Pa
Power source : 220-240V

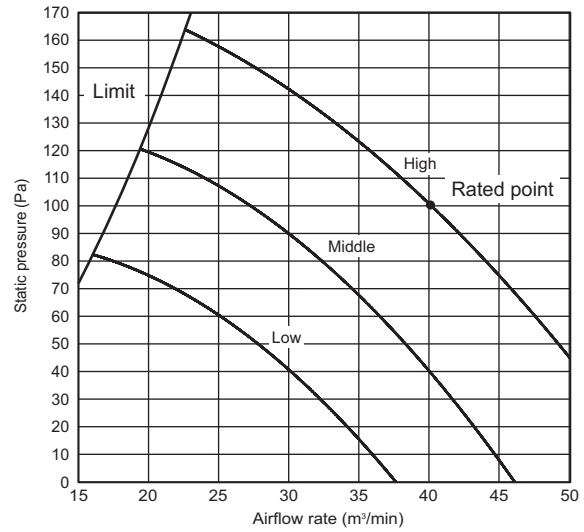

PEFY-P125VMA-E

External static pressure : 150Pa
Power source : 220-240V

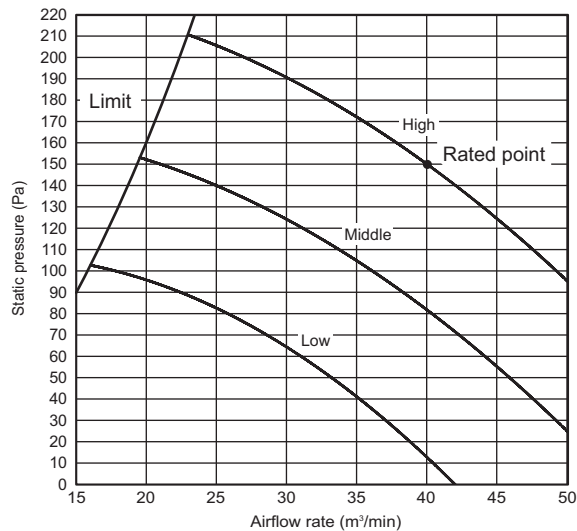

■ Optional parts line up for the Indoor unit

	Filter box
PEFY-P20, 25, 32VMA-E	PAC-KE91TB-E
PEFY-P40, 50VMA-E	PAC-KE92TB-E
PEFY-P63, 80VMA-E	PAC-KE93TB-E
PEFY-P100, 125VMA-E	PAC-KE94TB-E

● PEFY-P-VMA-E

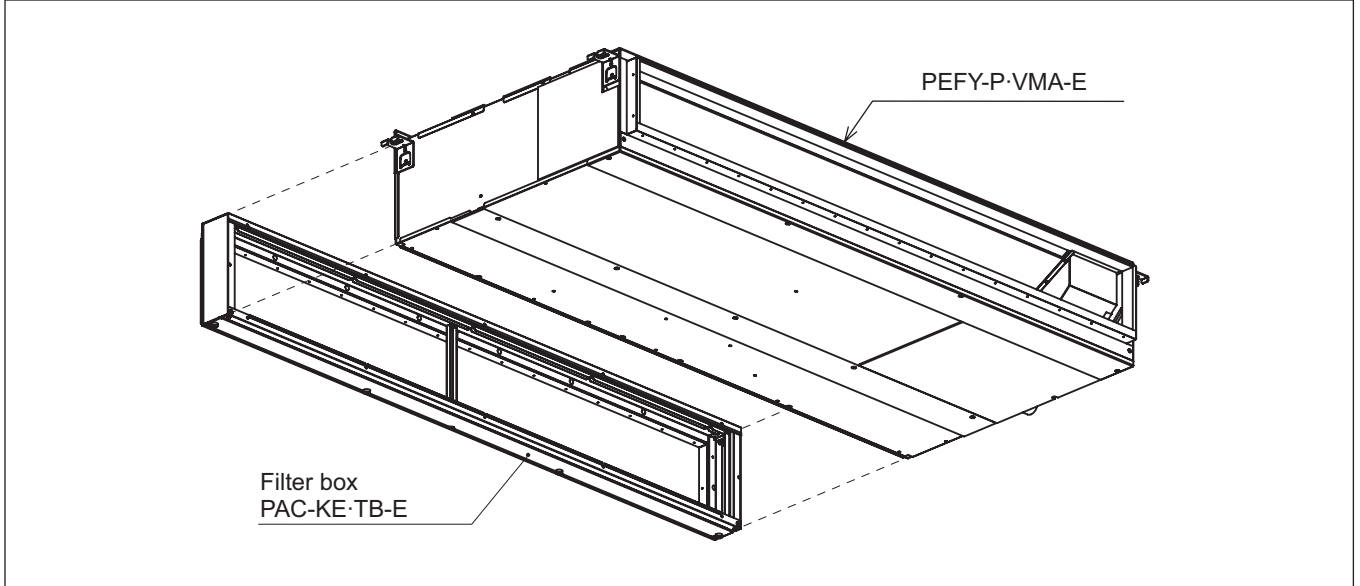

■ Filter box PAC-KE-TB-E for PEFY-P-VMA-E

PAC-KE-TB-E

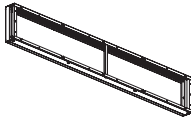
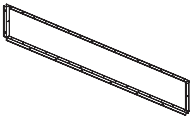
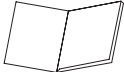
Item	1 Screw	2 Filter box	3 FLANGE	4 Installation manual	
Quantity	30	1	1	1	
Shape					

Detailed installation information should be referred to its Installation Manual (WT05704X01)

PEFY-VMA